



Equipped with AEM® Dryflow™ Filter
No Oil Required!

INSTALLATION INSTRUCTIONS

PART NUMBER:

21-415B	(Blue Finish)
21-415C	(Gun Metal Grey)
21-415P (Vacuum Metalized Chrome-VMC)	
21-415R	(Red Finish)

1998-2002 HONDA Accord L4-2.3L

C.A.R.B. E.O. # D-670-15

Excludes 2000 MY LEV II SULEV YHNXV02.3NL5, 2001 MY LEV II SULEV 1HNXV02.3BF9, 2002 MY LEV II SULEV 2HNXV02.3FK6 model year vehicles

PARTS LIST

Description	Qty.	Part Number
Element Parts Kit 2.50 X 5" Dry Ele.	1	21-201DK
Inlet Pipe	1	2-422
Hose, Silicone 2.50x3" Blk.	1	5-250
Mount, Rubber 1" X 6mm	1	1228599
Hose; 3/8"ID X 2"L	1	5-1002
Washer, 6mm Soft Mount	1	08160
Nut, M6 Hex Serrated	1	444.460.04
Hose Clamp, 3/4"	2	4093-5
1/2' Bnd. Hose Clamp, 2.15-3.00"	2	9440
1/2" Bnd. Hose Clamp, 2.31-3.25"	1	9444

Read and understand these instructions **BEFORE** attempting to install this product. Failure to follow installation instructions and not using the provided hardware may damage the intake tube, throttle body and engine.

The AEM® intake system is a performance product that can be used safely during mild weather conditions. During harsh and inclement weather conditions, you must return your vehicle to stock OEM air box and intake tract configuration. Failure to follow these instructions will void your warranty.

1. Preparing Vehicle

- a. Make sure vehicle is parked on level surface.
- b. Set parking brake.
- c. If engine has run in the past two hours, let it cool down.
- d. Disconnect negative battery terminal.
- e. Do not discard stock components after removal of the factory system.

2. Removal of stock system

- a. The following items will be removed from the vehicle.
 - i. The OE inlet tube.
 - ii. The air filter case.
 - iii. Intake air noise resonators. (Fig. A)
- b. Removal of intake air tube.
 - i. Disconnect the breather hose from the intake tube. The hose consists of a section of metal tubing between the intake tube and the cam cover.
- c. Removal of air filter case.
 - i. Remove the two mounting bolts for the air filter case and lift the case out.
- d. Raise the front of the vehicle with a jack. Refer to your owner's manual for proper jack and jack stand placement to properly support vehicle. Support your vehicle using properly rated jack stands before

wheel

removal or while working under the vehicle.

NEVER WORK UNDER A VEHICLE WITHOUT USING JACK STANDS.

- i. Remove the lower front splashguard (Fig. B)
 - ii. Remove the front left wheel. Then remove the necessary hardware and inner fender liner.
- e. Remove the bolts holding the lower resonator assembly and pull the assembly out from underneath the vehicle.
- f. Remove the two bolts securing the diagonal fender brace that is mounted between the battery and the passenger-side fender. (Fig. C)

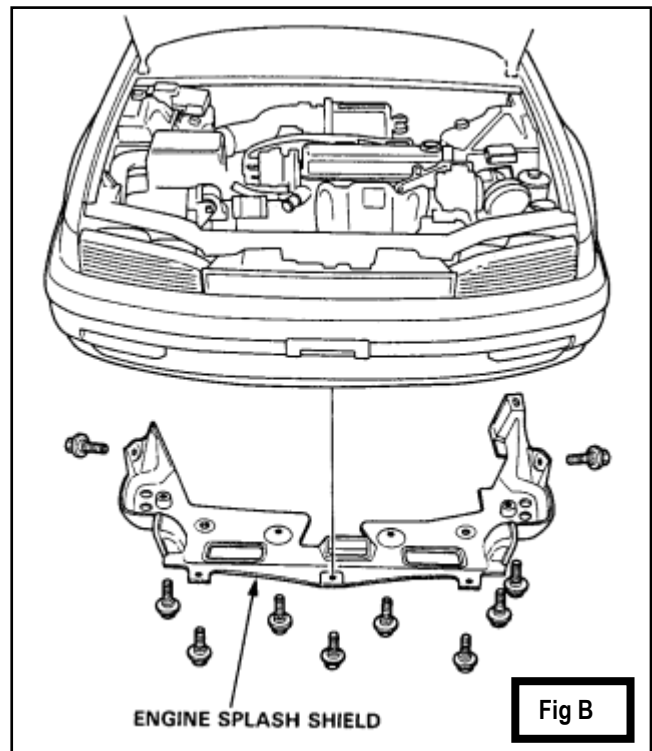
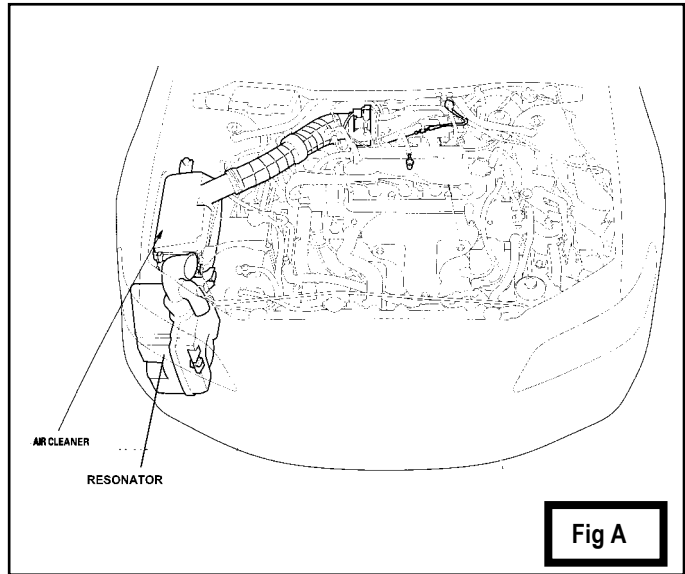

3. Installation of AEM[®] intake system.

- a. When installing the intake system, do not completely tighten the hose clamps or mounting hardware until instructed to do so.
- b. Install the hose section on the throttle body side (side opposite the bracket) of the intake pipe.
 - i. Install two 2¹/₂" hose clamps on each end of the hose and tighten them snugly enough to stay in place.
- c. Thread the supplied rubber mount into the threaded hole on the fender brace support area as shown in Fig. D. Reinstall the diagonal fender brace with the rubber mount now installed.
- d. Place the intake pipe into the engine bay.
 - i. Install the intake pipe onto the throttle body. Secure the two 2¹/₂" hose clamps snugly enough to hold the intake pipe in place but loosely enough so that the intake pipe's position may be adjusted.
 - ii. The air filter end of the intake pipe should pass through the hole in the fender where the brace was removed. (Fig. E)
 - iii. The rubber mount stud installed on the fender brace should line up with the bracket on the intake pipe.
- e. Install the large fender washer and the lock nut onto the isolator mount stud and secure it. (Fig. F)
NOTE: Failure to install the rubber mount will void all warranties of the intake system. Below is a diagram of how the rubber mount should be installed.
- f. Installing the air filter assembly.
 - i. Install the AEM air filter onto the end of the intake pipe. Push the air filter on about 2 inches over the intake pipe and secure with one hose clamp. Once fitment is checked, you can either push the air filter onto the intake pipe more or less depending on clearances. Tighten the hose clamp after proper fitment is achieved.
 - ii. Make sure there is adequate clearance around the intake pipe and air filter and ensure they do not come into contact with any part of the vehicle. (Fig. G)
- g. Once you are satisfied with the installation, completely tighten all the hose clamps and the rubber mount nut.
 - i. 2 hose clamps at the throttle body.
 - ii. 1 hose clamp at the air filter assembly.
- h. Install the 3/8" x 2" hose onto the metal valve cover breather tube that was removed in step 2bi. Use the remaining hose clamps to secure the breather hose onto the intake pipe and the metal valve cover breather tube. (Fig H)

4. Reassemble Vehicle

- a. **Fender liner and Lower Front Splashguard:** Install the fender liner, lower splashguard and any hardware that was removed in steps 2d i. and 2d ii.
NOTE: Failure to install the plastic splashguard will result in diminished performance and increase the potential for engine damage due to water ingestion in rainy conditions.
- b. **Wheel:** Install the front left wheel using the factory torque specification (see owner's manual).
- c. Position the inlet pipes for the best fitment. Be sure that the pipes or any other components do not contact any part of the vehicle. Tighten the rubber mount, all bolts, and hose clamps.
- d. Check for proper hood clearance. Re-adjust pipes if necessary and re-tighten them.
- e. Inspect the engine bay for any loose tools and check that all fasteners that were moved or removed are properly tightened.
- f. Reconnect negative battery terminals and start engine. Let the vehicle idle for 3 minutes. Perform a final inspection before driving the vehicle.



Fig. C

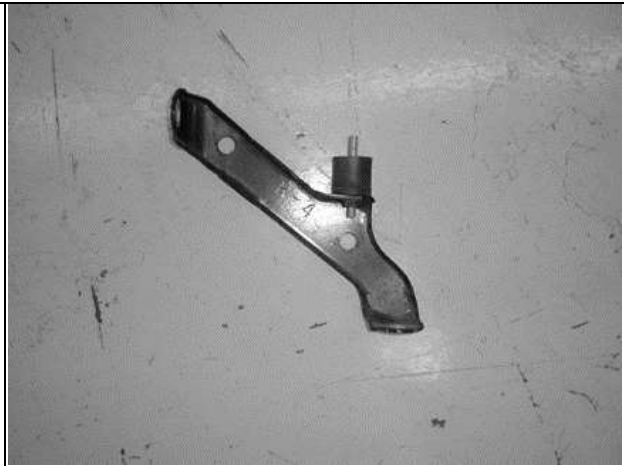

Fig. D



Fig. E

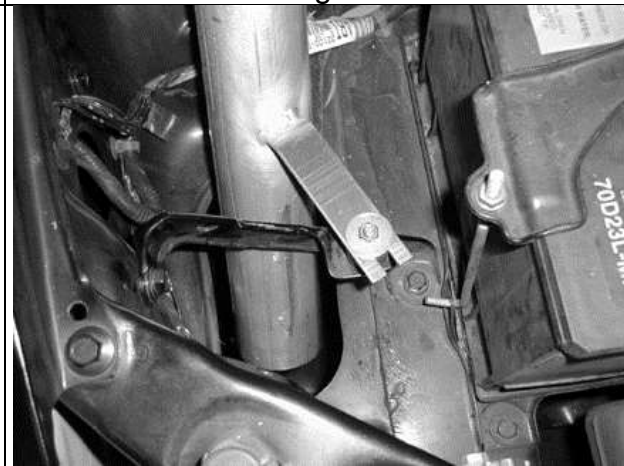

Fig. F

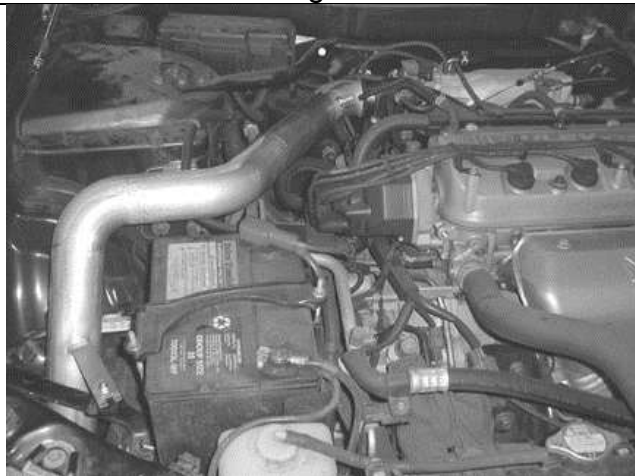

Fig. G

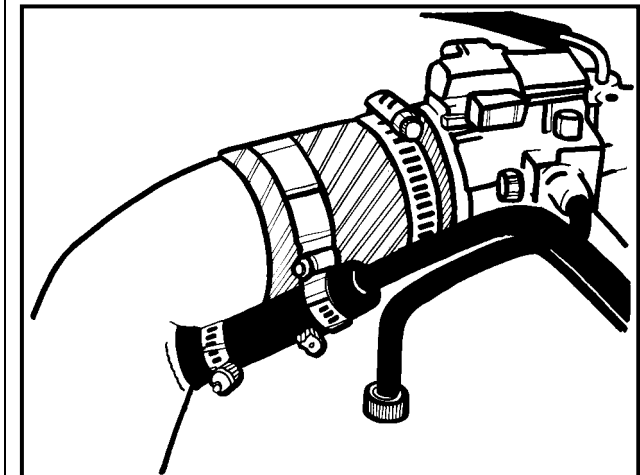

Fig. H

5. CARB Sticker Placement

- a. The C.A.R.B. exemption sticker, (attached), must be visible under the hood so that an emissions inspector can see it when the vehicle is required to be tested for emissions. California requires testing every two years, other states may vary.

6. Service and Maintenance

- a. It is recommended that you service your AEM[®] Dryflow™ filter every 20,000 miles for optimum performance. Use AEM Dryflow cleaning kit part # 21-110.
- b. Use aluminum polish to clean your polished AEM[®] intake tube.
- c. Use window cleaner to clean your powder coated AEM[®] intake tube. **(NOTE: DO NOT USE aluminum polish on powder coated AEM intake tubes).**