

THE INFORMATION CONTAINED IN THIS DRAWING IS THE SOLE PROPERTY OF  
 ADVANCED ENGINE MANAGEMENT, INC. ANY REPRODUCTION IN PART OR WHOLE WITHOUT  
 THE WRITTEN PERMISSION OF ADVANCED ENGINE MANAGEMENT, INC. IS PROHIBITED.

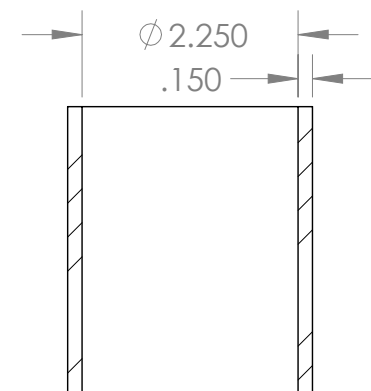
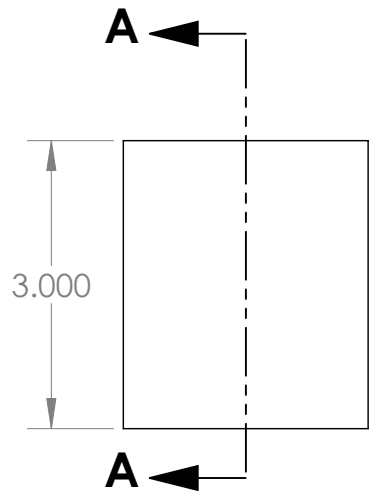
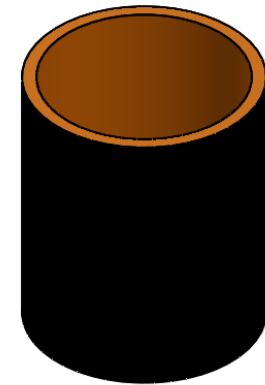
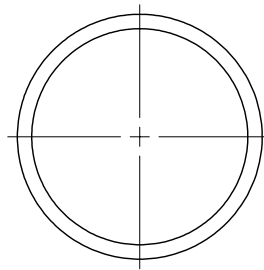

**SECTION A-A**

UNLESS OTHERWISE SPECIFIED  
 DIMENSIONS ARE IN INCHES  
 TOLERANCES ARE:  
 ±.X ±.XX ±.XXX  
 ±.06 ±.01 ±.005  
 ANGLES ±1°  
 CONCENTRICITY .010 T.I.R.

MATERIAL  
 REINFORCED SILICON RUBBER, COUPLER

FINISH  
 BLACK

PART  
 VOLUME 3.39

CAD GENERATED DRAWING,  
 DO NOT MANUALLY UPDATE  
 DO NOT SCALE DRAWING



TITLE  
 HOSE, SILICONE 2.25X3" BLK

SIZE A	DWG. NO. AEM-5-225 (ONLINE)	REV. A
-----------	--------------------------------	-----------

SCALE 1:2	<input type="radio"/> UK <input checked="" type="radio"/> USA	SHEET 1 OF 1
--------------	---	--------------