

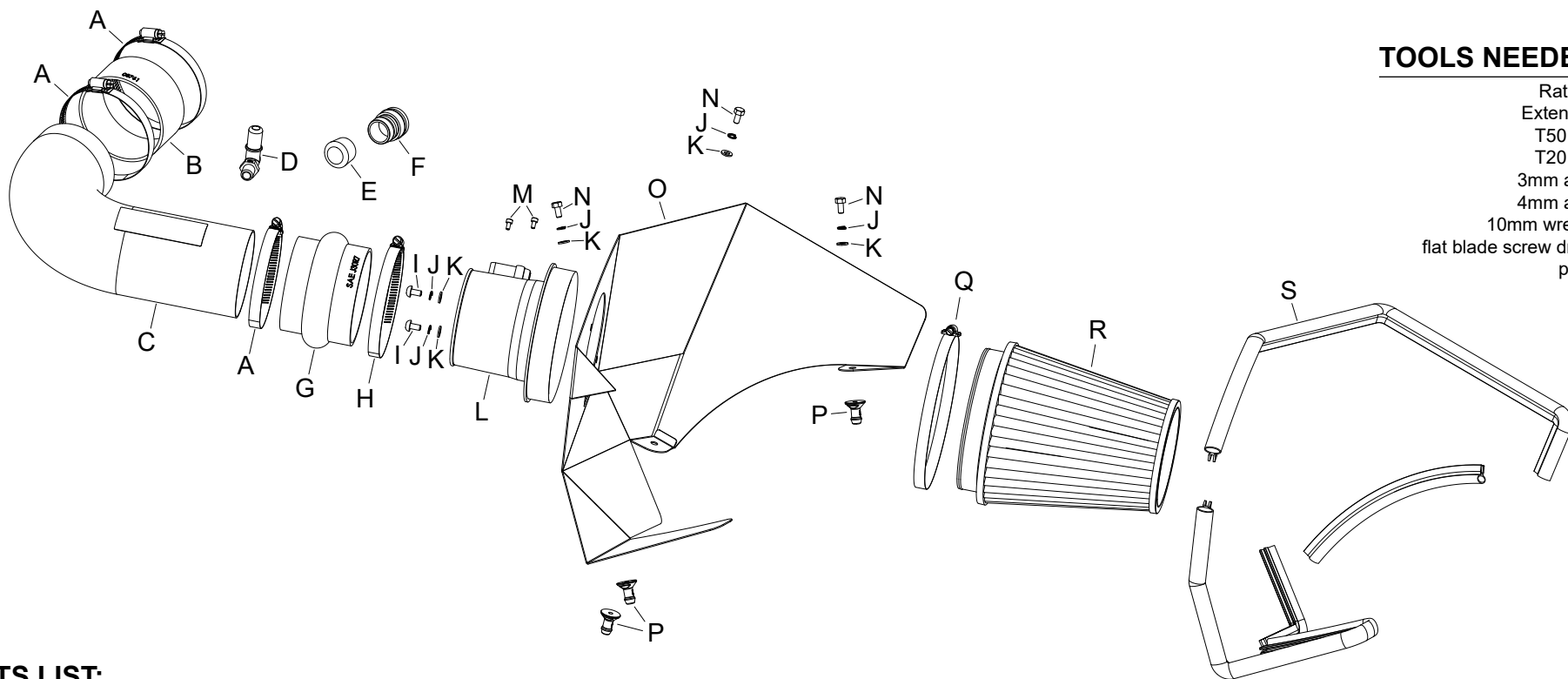

## INSTALLATION INSTRUCTIONS

**21-859C (Gun Metal Gray Finish)**  
**CHEVROLET**  
**2016-20 Camaro SS**  
**V8-6.2L**

NOT LEGAL FOR SALE OR USE ON ANY POLLUTION CONTROLLED MOTOR VEHICLE IN CALIFORNIA OR STATES ADOPTING CALIFORNIA EMISSION PROCEDURES.



### TOOLS NEEDED:

Ratchet  
 Extension  
 T50 torx  
 T20 torx  
 3mm allen  
 4mm allen  
 10mm wrench  
 flat blade screw driver  
 pliers

### PARTS LIST:

Description	Qty.	Part #	Description	Qty.	Part #	Description	Qty.	Part #
A HOSE CLAMP #64 STAINLESS	3	08645	H HOSE CLAMP #72	1	08671	O HEAT SHIELD	1	20-8644
B HOSE; 4"ID X 2"L REINFORCED	1	08761	I BOLT; M6 X 1.00" 12MM, SS	2	07794	P MOUNT, PLASTIC AIRBOX	3	8-186-1
C INTAKE TUBE	1	2-1630C	J WASHER, M6 SPLIT LOCK ZINC	5	1-3025	Q 1/2" BNDHOSE CLAMP, 4.125	1	94104
D VENT; 90"D, 1/4"NPT, TO .600"	1	82633	K WASHER; 6MM FLAT, SS	5	08269	R AIR FILTER	1	21-2100DK
E CAPLUG; 15/16" ID, 3/4" L, BLK	1	08246	L ADAPTER; MAF SENSOR	1	088035	S EDGE TRIM (75")	1	102460
F ADAPTOR; 1-1/8"OD QUICK	1	088012	M BOLT; M4 - 0.7 8MM, A/H CAP	2	07733			
G HOSE; HUMP 4"ID TO 4.19"ID	1	08633	N BOLT; M6 X 1.00 X 12MM, HEX	3	07727			

Read and understand these instructions **BEFORE** attempting to install this product. Failure to follow installation instructions and not using the provided hardware may damage the intake tube, throttle body and engine.

### TO START:

1. Turn off the ignition and disconnect the negative battery cable.  
**NOTE: Disconnecting the negative battery cable erases pre-programmed electronic memories. Write down all memory settings before disconnecting the negative battery cable. Some radios will require an anti-theft code to be entered after the battery is reconnected. The anti-theft code is typically supplied with your owner's manual. In the event your vehicles anti-theft code cannot be recovered, contact an authorized dealership to obtain your vehicles anti-theft code.**



2. Disconnect the mass air sensor electrical connection.



3. Disconnect the crank case vent quick disconnect from the factory intake tube.



4. Release the spring clamp that secures the sound tube to the intake tube and then disconnect the sound tube.



5. Loosen the hose clamps that secure the factory intake tube and then remove the intake tube from the vehicle.



6. Remove the two bolts that secure the sound drum to the engine.



7. Open the clamp that secures the sound tube to the factory air filter housing.



8. Disconnect the sound tube from the A/C line.



9. Disconnect the sound tube quick disconnect and then remove the complete sound tube assembly.



10. Assemble the provided quick disconnect fitting and cap plug.



11. Install the cap plug assembly into the remaining factory sound tube quick connect fitting.



12. Remove the factory air filter housing from the vehicle.

**NOTE: AEM recommends that customers do not discard factory air intake.**



13. Install the provided mass air sensor housing into the provided heat shield and secure with the hardware provided.



14. Cut the provided edge trim into three sections of 9", 30" and 33"



15. Install the edge trim onto the heat shield. Install the three provided mounting studs using the hardware provided.



16. Remove the mass air sensor from the factory air filter housing and install it into the AEM® air filter housing using the provided hardware.



17. Install the heat shield assembly into the vehicle so the mounting studs engage the factory grommets.



18. Install the provided coupler (08761) onto the throttle body and secure with the provided hose clamps.



19. Install the provided hump coupler (08633) onto the mass air sensor housing and secure with the provided hose clamps.



20. Install the 90° vent fitting into the AEM® intake tube as shown.

**NOTE: Plastic NPT fittings are easy to cross thread. Install the vent fitting "hand" tight, then turn it two complete turns with a wrench.**



21. Install the AEM® intake tube into the hump coupler and then into the coupler at the throttle body, adjust the tube for best fit and then secure with the provided hose clamps.



22. Connect the factory crank case vent line to the quick connect fitting installed into the AEM® intake tube.



23. Reconnect the mass air sensor electrical connection.



24. Install the AEM® air filter and secure with the provided hose clamp.



### Reassemble Vehicle

Position the inlet pipes for the best fitment. Be sure that the pipes or any other components do not contact any part of the vehicle. Tighten the rubber mount, all bolts, and hose clamps. Check for proper hood clearance. Re-adjust pipes if necessary and re-tighten them. Inspect the engine bay for any loose tools and check that all fasteners that were moved or removed are properly tightened. Reconnect negative battery terminal and start engine. Let the vehicle idle for 3 minutes. Perform a final inspection before driving the vehicle.

### Service and Maintenance

AEM Induction Systems requires cleaning the intake system's air filter element every 100,000 miles. When used in dusty or off-road environments, our filters will require cleaning more often. We recommend that you visually inspect your filter once every 25,000 miles to determine if the screen is still visible. When the screen is no longer visible some place on the filter element, it is time to clean it. To clean, purchase our Synthetic air filter cleaner, part number 99-0624 and follow the easy instructions. Use window cleaner to clean your powder coated AEM® intake tube.

**NOTE: DO NOT USE aluminum polish on powder coated AEM® intake tubes.**

**NOT LEGAL FOR SALE OR USE ON ANY POLLUTION CONTROLLED MOTOR VEHICLE IN CALIFORNIA OR STATES ADOPTING CALIFORNIA EMISSION PROCEDURES.**