



Equipped with AEM® Dryflow™ Filter
No Oil Required!

INSTALLATION INSTRUCTIONS
PART NUMBER
21-807C (GUN METAL GRAY FINISH)

2016

INFINITI

Q50

2.0T

ITEM NO.	PART NUMBER	DESCRIPTION	QTY.
1	21-2128DK	AIR FILTER; 2-3/4" X 6-7/8" OVAL DRYFLOW	1
2	2-1589C	INTAKE TUBE; 2.5"OD X 5.25", 21-807C, GUNMETAL	1
3	20-8589B	HEAT SHIELD; INFINITI Q50 2.OT, W/BADGE	1
4	8-4036	EDGE TRIM, 36"	1
5	08601K	HOSE CLAMP #48, BLACK ZINC PLATED	1
6	1-112	BOLT; BUTTON HEAD M6-1.0 X 10MM, SS	3
7	1-3025	WASHER, M6 SPLIT LOCK ZINC	3
8	1-2038	BOLT; HEX/FLANGE M6-1 X 20	2
9	079195	SPACER;.5"OD X .25"ID X.5"L, B/O	2
10	8-167	NEOPRENE, 1/16" X 1" ROUND ADHESIVE	1

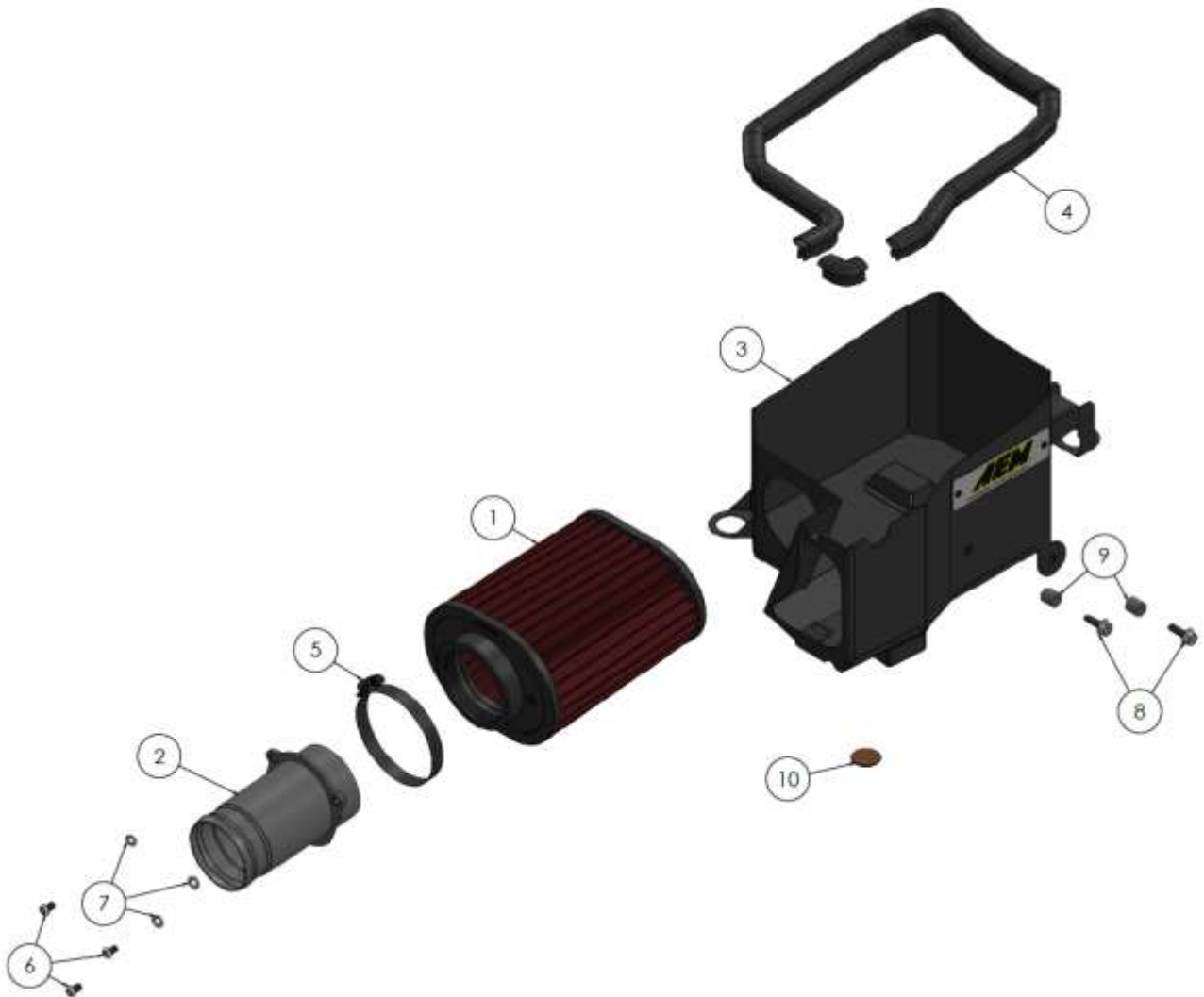

Read and understand these instructions **BEFORE** attempting to install this product. Failure to follow installation instructions and not using the provided hardware may damage the intake tube, throttle body and engine.

Tools Needed:	Optional:
7mm, 8mm Socket Driver	Small Torque Wrench
10mm Wrench	Heat Gun
4mm Hex Key	
Side Cutters	

1. Preparing Vehicle

- Make sure vehicle is parked on level surface.
- Set the parking brake.
- If engine has run in the past two hours, let it cool down.
- Disconnect negative battery terminal.
- Do not discard stock components after removal of the factory system.
- Open the air intake kit package and make sure all parts are included.

2. Removal of stock system



a. Carefully pull up on the engine cover and remove it.



b. Pull the intake scoop from the air box and move it aside.



c. Loosen the hose clamp securing the air box to the turbo inlet pipe using a 7mm nut driver.



d. Remove the evaporative emissions (EVAP) hardline from the clip.



e. Pull up on the air box so that the (3) grommets are unseated from their posts. Then separate the air box from the turbo inlet pipe. Heating the turbo inlet pipe with a heat gun will help with the separation process.



f. Rotate the air box to gain as much access to the (2) M6 bolts fastening the EVAP hardline to the air box. Remove the (2) M6 bolts with a 10mm wrench. Do not discard any factory hardware.



g. Remove the air box from the engine bay. Do not discard any factory components.



h. Remove the (3) grommets from the air box. You will install these onto the AEM air box in step 3b.

3. Installation of AEM® intake system.

a. When installing the intake system, do not completely tighten the hose clamps or mounting hardware until instructed to do so.



a. Line the upper edge of the AEM air box with the supplied edge trim as shown.



b. Install the (3) grommets removed from the factory air box onto the AEM air box as shown. Also apply the neoprene adhesive pad in the location shown.



c. Install the intake tube onto the air box with the supplied (3) M6 bolts and (3) split lock washers.



d. Make sure the edge on the tube flange coincides with the corresponding edge of the air box.



e. Install the AEM air filter assembly with hose clamp into the air box and tighten to 30 in-lbs.



g. Angle the air box to gain as much access to the side as shown. The supplied spacers will go in between the EVAP hardline and the air box. Use the supplied M6 x 20mm bolts to fasten the hardline bracket closest to the firewall. Then, fasten the hardline bracket towards the front of the vehicle.



i. Insert the intake scoop into the air box. Make sure the retaining tabs on the air box lock onto the intake scoop.



f. Place the air box assembly into the engine bay. Insert the intake tube into the turbo inlet pipe. Do not tighten the hose clamp yet and do not seat the grommets onto their posts at this time.



h. Push down on the air box to fully seat the grommets onto their respective posts. Tighten the hose clamp and reach the EVAP hardline to the clip.



j. Reinstall the engine cover. AEM recommends you retain the use of the engine cover as the edge trim on the AEM air box is designed to seal with the engine cover to keep intake air temperatures at a minimum.



STOCK INTAKE INSTALLED (ENGINE COVER REMOVED)



AEM INTAKE INSTALLED (ENGINE COVER REMOVED)

4. Reassemble Vehicle

- a. Position all kit components for best fitment. Ensure that no components contact any unintended part of the vehicle.
- b. Check for proper hood clearance. Re-adjust components if necessary and re-tighten them.
- c. Inspect the engine bay for any loose tools and ensure that all fasteners that were moved or removed are properly tightened.
- d. Reconnect negative battery terminal and start engine. Let the vehicle idle for 3 minutes. Perform a final inspection before driving the vehicle.

5. Service and Maintenance

- a. AEM Induction Systems requires cleaning the intake system's air filter element every 100,000 miles. When used in dusty or off-road environments, our filters will require cleaning more often. We recommend that you visually inspect your filter once every 25,000 miles to determine if the screen is still visible. When the screen is no longer visible some place on the filter element, it is time to clean it. To clean, purchase our Synthetic air filter cleaner, part number 1-1000 and follow the easy instructions.
- b. Use window cleaner to clean your powder coated AEM[®] intake tube.

NOTE: DO NOT USE aluminum polish on powder coated AEM[®] intake tubes.