

CHEVY V8 ENGINE TO S10-S15 2WD

KIT CONSISTS OF:

<u>No.</u>	<u>Qty</u>	<u>Part No.</u>	<u>Description</u>
1.	1	713111-L	DRIVER'S SIDE ENGINE MOUNT
2.	1	713111-R	PASSENGER SIDE ENGINE MOUNT
3.	1	714200	BOLT PACK
4.	1	GM001	GM INSTRUCTION MANUAL

INSTALLATION PROCEDURES:

These engine mounts are designed to bolt over the original S10 2.8 V6 engine rubbers. When used with the TH350 transmission or the original T4/T5 manual transmission, driveshaft modifications will not be required. The engine mounts work best by first installing the welded mounts over the V6 rubbers. Install the special 7/16" hex head bolt through the rubber and into the Advance Adapter support. Once the mounts are in position, the engine can then be positioned into the chassis for final assembly.

The engine mounts have two different engine position locations. The Advance Adapters brackets have two hole locations for the special 7/16" bolt. The upper hole will position the engine approximately 1" higher than the lower hole. The height will make a significant difference in your exhaust system requirements. We suggest that you trial fit the engine mounts to determine your best choice. Lower locations are usually required on vehicles that have been lowered. Advance Adapters recommends using the upper location whenever possible. If you select the lower location, the engine mounts will need to be modified for the additional clearance and the upper hole will need to be removed.

LOWER ENGINE POSITION:

Optional stock manifolds that fit late model engines only
Modification for starter motor clearance over engine support is necessary
Modification to the engine mounts for the removal of the upper hole
Slick Fit Headers are not available.

UPPER ENGINE POSITION:

Advance Adapter "Slick Fit" header No. 717052
Stock Manifolds (1987 & newer Low Performance car)
No modifications to the engine mounts

NOTE: *You may need to grind the small metal tabs located on both sides on your stock 2.8 liter V6 rubber mounts. This may be required to fit the Advance Adapter engine mounts over your stock rubber mounts.*

SPECIAL NOTE: The components packaged in this kit have been assembled and machined for specific type of conversions. Modifications to any of the components will void any possible warranty or return privileges. If you do not fully understand modifications or changes that will be required to complete your conversion, we strongly recommend that you contact our sales department for more information. This instruction sheet is only to be used for the assembly of Advance Adapter components. We recommend that a service manual pertaining to your vehicle be obtained for specific torque values, wiring diagrams and other related equipment. These manuals are normally available at automotive dealerships and parts stores.

CHEVY V8 ENGINE TO S10-S15 2WD

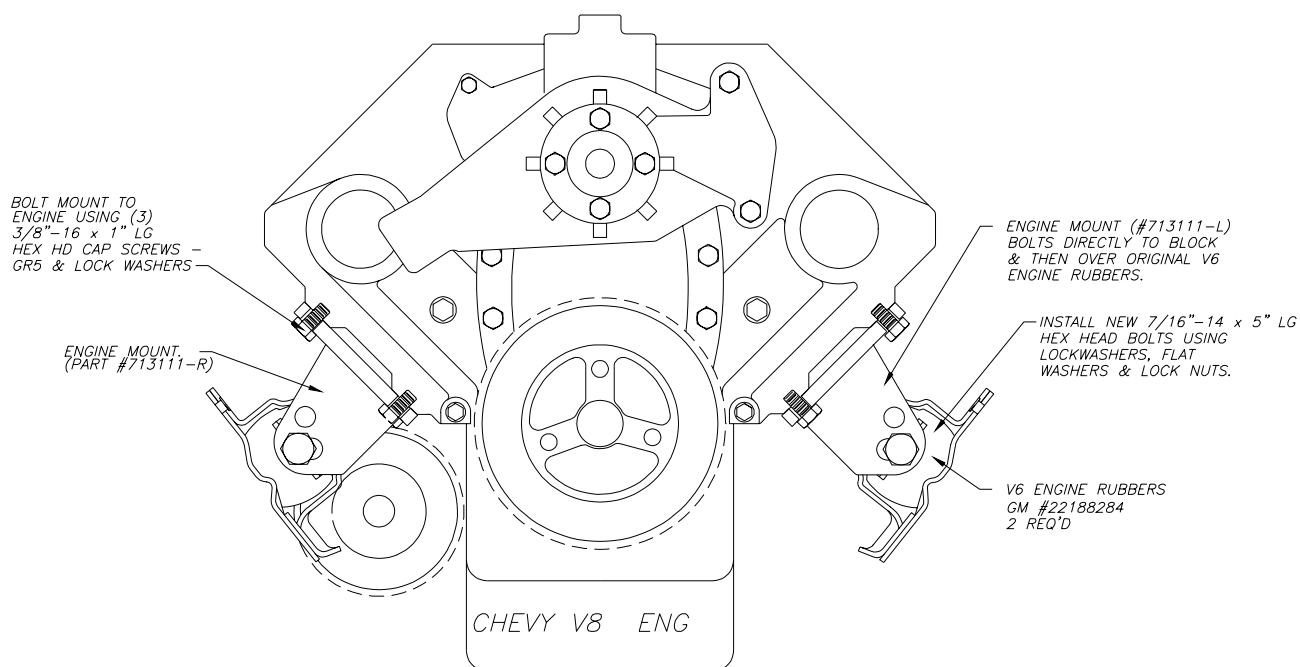

NOTE: If you are using a late model block that utilizes an engine block sensor, you will need to purchase a Brass Street Elbow Dorman, Part #490-117. This will allow you to retain your sensor in the original location in order for the block to operate correctly.

SPECIAL NOTE: The components packaged in this kit have been assembled and machined for specific type of conversions. Modifications to any of the components will void any possible warranty or return privileges. If you do not fully understand modifications or changes that will be required to complete your conversion, we strongly recommend that you contact our sales department for more information. This instruction sheet is only to be used for the assembly of Advance Adapter components. We recommend that a service manual pertaining to your vehicle be obtained for specific torque values, wiring diagrams and other related equipment. These manuals are normally available at automotive dealerships and parts stores.