

CHEVY V8 ENGINE TO S10-S15 4WD VEHICLES

KIT CONSISTS OF:

<u>No.</u>	<u>Qty</u>	<u>Part No.</u>	<u>Description</u>
1.	1	713107L	DRIVER'S SIDE ENGINE MOUNT
2.	1	713107R	PASSENGER SIDE ENGINE MOUNT
3.	1	714200	BOLT PACK
4.	1	GM001	GM INSTRUCTION MANUAL

INSTALLATION PROCEDURES:

These engine mounts are designed to bolt over the original S10 2.8 V6 engine rubbers. When used with the TH350 transmission or the original T4/T5 manual transmission, driveshaft modifications will not be required. The engine mounts work best by first installing the welded mounts over the V6 rubbers. Install the special 7/16" hex head bolt through the rubber and into the Advance Adapters support. Once the mounts are in position, the engine can then be positioned into the chassis for final assembly.

The engine must be equipped with the Advance Adapters rear sump oil pan and the special oil pickup tube. With the engine location, you will have the option of using the Advance Adapter "Slick Fit" headers, No. 717053, or stock manifolds. For additional information, refer to the GM instruction manual.



NOTE: You may need to grind the small metal tabs located on both sides on your stock 2.8 liter V6 rubber mounts. This may be required to fit the Advance Adapter engine mounts over your stock rubber mounts.

ALSO: If you are using a late model block that utilizes an engine block sensor, you will need to purchase a Brass Street Elbow Dorman, Part #490-117. This will allow you to retain your sensor in the original location in order for the block to operate correctly.

SPECIAL NOTE: The components packaged in this kit have been assembled and machined for specific type of conversions. Modifications to any of the components will void any possible warranty or return privileges. If you do not fully understand modifications or changes that will be required to complete your conversion, we strongly recommend that you contact our sales department for more information. This instruction sheet is only to be used for the assembly of Advance Adapter components. We recommend that a service manual pertaining to your vehicle be obtained for specific torque values, wiring diagrams and other related equipment. These manuals are normally available at automotive dealerships and parts stores.

**CHEVY V8 ENGINE TO S10-S15
4WD VEHICLES**

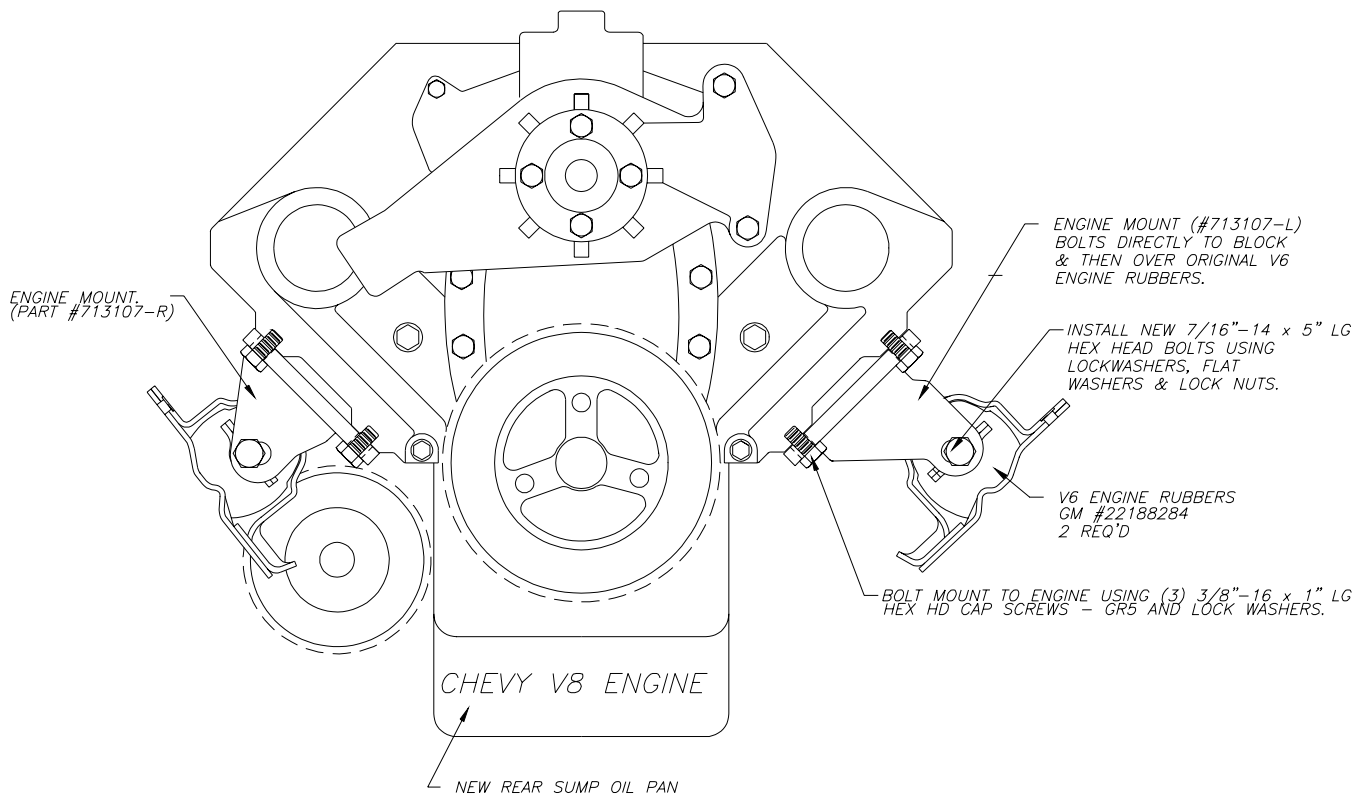

SPECIAL NOTE: The components packaged in this kit have been assembled and machined for specific type of conversions. Modifications to any of the components will void any possible warranty or return privileges. If you do not fully understand modifications or changes that will be required to complete your conversion, we strongly recommend that you contact our sales department for more information. This instruction sheet is only to be used for the assembly of Advance Adapter components. We recommend that a service manual pertaining to your vehicle be obtained for specific torque values, wiring diagrams and other related equipment. These manuals are normally available at automotive dealerships and parts stores.