

## ATLAS YOKE ASSEMBLIES

**P/N A1310-26 - 26 SPLINE NON CV 1310 YOKE KIT**

- |    |   |        |   |
|----|---|--------|---|
| 1. | 1 | 300477 | 1310 NON CV YOKE REQUIRES SEAL (NAT.450185) |
| 2. | 1 | 300478 | NUT (JEEP # 1791575)                        |

**P/N A1310CV26 - 26 SPLINE CV 1310 YOKE KIT**

- |    |   |        |   |
|----|---|--------|---|
| 1. | 1 | 300481 | 1310 CV YOKE REQUIRES SEAL (NAT.450185) |
| 2. | 1 | 300478 | NUT (JEEP # 1791575)                    |

**P/N A1310 - 32 SPLINE NON CV 1310 YOKE KIT**

- |    |   |        |                   |
|----|---|--------|-------------------|
| 1. | 1 | 716295 | 1310 NON CV YOKE  |
| 2. | 1 | 300473 | SEAL (NAT.472015) |
| 3. | 1 | 300476 | NUT               |

**P/N A1310CV - 32 SPLINE CV 1310 YOKE KIT**

- |    |   |        |                      |
|----|---|--------|----------------------|
| 1. | 1 | 300475 | 1310 CV YOKE         |
| 2. | 1 | 300502 | SEAL (NAT.473239)    |
| 3. | 1 | 300476 | NUT (JEEP # 4167924) |

**P/N A1330CV - 32 SPLINE CV 1330 YOKE KIT**

- |    |   |        |                      |
|----|---|--------|----------------------|
| 1. | 1 | 300369 | 1330 CV YOKE         |
| 2. | 1 | 300502 | SEAL (NAT.473239)    |
| 3. | 1 | 300476 | NUT (JEEP # 4167924) |

**P/N A1350 - 32 SPLINE NON CV 1350 YOKE KIT**

- |    |   |        |                      |
|----|---|--------|----------------------|
| 1. | 1 | 300472 | 1350 NON CV YOKE     |
| 2. | 1 | 300473 | SEAL (NAT.472015)    |
| 3. | 1 | 300476 | NUT (JEEP # 4167924) |

**P/N A1350CV - 32 SPLINE CV 1350 YOKE KIT**

- |    |   |        |                      |
|----|---|--------|----------------------|
| 1. | 1 | 300485 | 1350 CV YOKE         |
| 2. | 1 | 300473 | SEAL (NAT.472015)    |
| 3. | 1 | 300476 | NUT (JEEP # 4167924) |

**P/N 1399 - 32 SPLINE NO YOKE**

- |    |   |        |                      |
|----|---|--------|----------------------|
| 1. | 1 | 300473 | SEAL (NAT.472015)    |
| 2. | 1 | 300476 | NUT (JEEP # 4167924) |

**P/N A399CV - 32 SPLINE NOYOKE SMALL SEAL**

- |    |   |        |                      |
|----|---|--------|----------------------|
| 1. | 1 | 300473 | SEAL (NAT.472015)    |
| 2. | 1 | 300476 | NUT (JEEP # 4167924) |

**P/N A1410 - 32 SPLINE NON CV 1410 YOKE KIT Strap style yoke**

- |    |   |        |                      |
|----|---|--------|----------------------|
| 1. | 1 | 300483 | 1410 NON CV YOKE     |
| 2. | 1 | 300473 | SEAL (NAT.472015)    |
| 3. | 1 | 300476 | NUT (JEEP # 4167924) |

**SPECIAL NOTE:** The components packaged in this kit have been assembled and machined for specific type of conversions. Modifications to any of the components will void any possible warranty or return privileges. If you do not fully understand modifications or changes that will be required to complete your conversion, we strongly recommend that you contact our sales department for more information. This instruction sheet is only to be used for the assembly of Advance Adapter components. We recommend that a service manual pertaining to your vehicle be obtained for specific torque values, wiring diagrams and other related equipment. These manuals are normally available at automotive dealerships and parts stores.

## ATLAS FLANGE YOKE ASSEMBLIES

**P/N A1410U - 32 SPLINE NON CV 1410 YOKE KIT U-Bolt style yoke**

1.	1	300488	1410 NON CV YOKE
2.	1	300473	SEAL (NAT.472015)
3.	1	300476	NUT (JEEP # 4167924)

**P/N AF1300 - 32 SPLINE 1310/1330/1350 FLANGE YOKE KIT**

1.	1	300470	1300 SERIES YOKE
2.	1	300473	SEAL (NAT.472015)
3.	1	300476	NUT (JEEP # 4167924)

**P/N AF1300S - 32 SPLINE 1350 FLANGE YOKE KIT**

1.	1	300468	YOKE- FLANGE 1350
2.	1	300473	SEAL (NAT.472015)
3.	1	300476	NUT (JEEP # 4167924)

**P/N AF1350 - 32 SPLINE 1350 FLANGE YOKE KIT**

1.	1	300450	1410 Flange Yoke 3.125" Male Pilot 3.00" square Bolt-Pattern
2.	1	300473	SEAL (NAT.472015)
3.	1	300476	NUT (JEEP # 4167924)

**P/N AF1410 - 32 SPLINE FLANGE 1410 YOKE KIT**

1.	1	300471S	1410 NON CV YOKE
2.	1	300473	SEAL (NAT.472015)
3.	1	300476	NUT (JEEP # 4167924)
4.	4	720084	12mm X 1.25TH X 25mm S.H.C.S.

**P/N AF1410STD - 32 SPLINE FLANGE 1410 YOKE KIT**

1.	1	300489	1410 NON CV YOKE
2.	1	300473	SEAL (NAT.472015)
3.	1	300476	NUT (JEEP # 4167924)

**P/N AF1480 - 32 SPLINE FLANGE 1480 YOKE KIT**

1.	1	716294	1480 FLANGE YOKE
2.	1	300473	SEAL (NAT.472015)
3.	1	300476	NUT (JEEP # 4167924)

**P/N AFTOY - 32 SPLINE FLANGE TOYOTAYOKE KIT**

1.	1	300465	TOYOTA YOKE
2.	1	300473	SEAL (NAT.472015)
3.	1	300476	NUT (JEEP # 4167924)

1410 non C.V. flange yoke. Spicer companion yoke number is 3-2-439 (1410 non-C.V.)

**SPECIAL NOTE:** The components packaged in this kit have been assembled and machined for specific type of conversions. Modifications to any of the components will void any possible warranty or return privileges. If you do not fully understand modifications or changes that will be required to complete your conversion, we strongly recommend that you contact our sales department for more information. This instruction sheet is only to be used for the assembly of Advance Adapter components. We recommend that a service manual pertaining to your vehicle be obtained for specific torque values, wiring diagrams and other related equipment. These manuals are normally available at automotive dealerships and parts stores.

## ATLAS FLANGE YOKE ASSEMBLIES

Flange yoke may require the companion flange bolts to be installed through the yoke before the yoke is installed onto the transfer case. This does depend on the series of companion yokes used. If the flange yoke is currently installed on your transfer case, you may be required to first loosen the yoke retaining nut, pull the yoke away from the transfer case enough to install the companion flange bolts. Once the bolts are in place a new lock nut should always be installed and torqued to 150 ft./lbs. to secure the yoke to the transfer case.

Torque specifications:

32 spline shafts 150 ft.lbs.

26 spline shafts 135 ft.lbs

If any yoke nut is ever removed from the shaft for any reason, it should always be replaced with a new one. When installing a new yoke, silicon should be used on the splines of the yoke, this is to prevent oil leakage down the shaft splines.

**NOTE:** Flange yokes that are installed onto a new Atlas Transfer Case are not fully torqued. The nuts must be torqued after the Atlas is installed into your vehicle.

**SPECIAL NOTE:** The components packaged in this kit have been assembled and machined for specific type of conversions. Modifications to any of the components will void any possible warranty or return privileges. If you do not fully understand modifications or changes that will be required to complete your conversion, we strongly recommend that you contact our sales department for more information. This instruction sheet is only to be used for the assembly of Advance Adapter components. We recommend that a service manual pertaining to your vehicle be obtained for specific torque values, wiring diagrams and other related equipment. These manuals are normally available at automotive dealerships and parts stores.

## ATLAS SHAFT & YOKE UPDATES

Advance Adapters has started a change in product design with the mating components of its rear output shaft, front output shafts, and on divorced unit front input shaft.

These updates started in 2017 with the new flat tow option on the Atlas and expanded into 2018 to include the standard Atlas 2 speed and 4 speed.

The flat tow rear output shaft is numbered 317124, setting it apart for recognition as the newer design. The standard design Atlas shafts were updated in 2018 are numbered 318124, 318123, 318016A. We kept the ending 3 digits the same as the earlier shafts. These new shafts will completely supercede the old design in the future.

These shafts will normally be part of a assembly bill of materials that we have labeled as a -T3 or -G3 at the end of the assembly part number.

The updated shafts will require an update to the yoke to work correctly.

The updated shafts will require the yoke to have a counter bore for indexing to the shaft. We are currently updating all of the yokes we produce to have this counter bore. The simplicity of this design is that it will work fine on ALL earlier shaft applications. Any yoke that is not counter bored WILL NOT WORK on the new style shafts.

### Summary:

All Advance Adapters shafts, New and Old will work with the new yokes that are counter bored.

Old yokes NOT counter bored will still work on the older shaft, but would require the counter bore to work on the new design shafts.

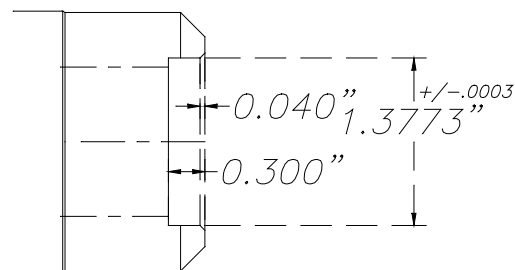
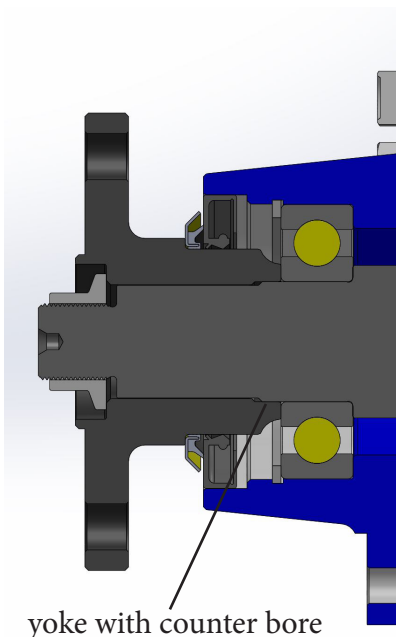

**SPECIAL NOTE:** The components packaged in this kit have been assembled and machined for specific type of conversions. Modifications to any of the components will void any possible warranty or return privileges. If you do not fully understand modifications or changes that will be required to complete your conversion, we strongly recommend that you contact our sales department for more information. This instruction sheet is only to be used for the assembly of Advance Adapter components. We recommend that a service manual pertaining to your vehicle be obtained for specific torque values, wiring diagrams and other related equipment. These manuals are normally available at automotive dealerships and parts stores.