

JEEP 304, 360 & 401 MOTOR MOUNT ASSEMBLY

KIT CONSISTS OF:

| <u>No.</u> | <u>Qty</u> | <u>Part No.</u> | <u>Description</u> |
|------------|------------|-----------------|--|
| 1. | 1 | 713120L | LEFT MOUNT |
| 2. | 2 | 713120F | FRAME MOUNTS |
| 3. | 2 | 713120M | ENGINE MOUNTING BRACKETS (<i>Jeep #52019201AB</i>) |
| 4. | 1 | 713120R | RIGHT MOUNT |
| 5. | 2 | 720011 | 10mm x 1.5" NUT |
| 6. | 2 | 720038 | 10mm LOCKWASHERS |
| 7. | 2 | 723701 | 3/8" HEX NUTS |
| 8. | 8 | 723704 | 3/8" LOCK WASHERS |
| 9. | 8 | 723721 | 3/8"-16 x 1 LG. H.H.C.S. (<i>Grade5</i>) |
| 10. | 10 | 723735 | 3/8" FLAT WASHERS |
| 11. | 2 | 725001 | 1/2"-13 x 4.5" GRD. 5 BOLT |
| 12. | 2 | 725002 | 1/2" LOCK WASHERS |
| 13. | 4 | 725003 | 1/2" FLAT WASHERS |
| 14. | 2 | 725004 | 1/2" NUTS |

NOTES:

The frame brackets are designed to be welded into the Jeep frame rails. The rubber mounts bolt on top of the frame brackets. Slots are provided in the frame brackets to allow for different frame widths. You can also rotate the rubber support on the frame brackets to allow for narrow frame rails. If this is done, you may need to trim the outer edge of the frame bracket so it does not interfere with the engine block.

These mounts fit all Jeep CJ5s, CJ7s and YJ Wranglers. The "L" brackets are a universal weld in style. To set the block into the frame rails, we recommend that you assemble the mounts to the block with the rubber support & frame bracket assembly. Bolt the block to the AMC transmission. Make sure the block is in a level position. Mark your frame where the frame brackets are located. Weld the mounts and secure all bolts.

The following AMC blocks all have the same bolt pattern: 258 6-cyl., 4.2L, 4.0L, 304 V8, 360 V8 and 401 V8. **NOTE:** On automatic transmissions, the only difference with these blocks is that the flexplates are balanced differently. Make sure you match the flexplate with you block.

CAUTION:

These mounts are designed to mount different AMC V8 blocks into the various Jeep frame rails. Modifications to the drivetrain may be necessary on some applications. For example: Automatic transmissions may have shift linkage problems and fill tube interference. Manual transmissions sometimes have clutch linkage problems. **BEFORE** beginning your installation, consider what areas may be effected.

SPECIAL NOTE: The components packaged in this kit have been assembled and machined for specific type of conversions. Modifications to any of the components will void any possible warranty or return privileges. If you do not fully understand modifications or changes that will be required to complete your conversion, we strongly recommend that you contact our sales department for more information. This instruction sheet is only to be used for the assembly of Advance Adapter components. We recommend that a service manual pertaining to your vehicle be obtained for specific torque values, wiring diagrams and other related equipment. These manuals are normally available at automotive dealerships and parts stores.

**JEEP 304, 360 & 401
MOTOR MOUNT ASSEMBLY**

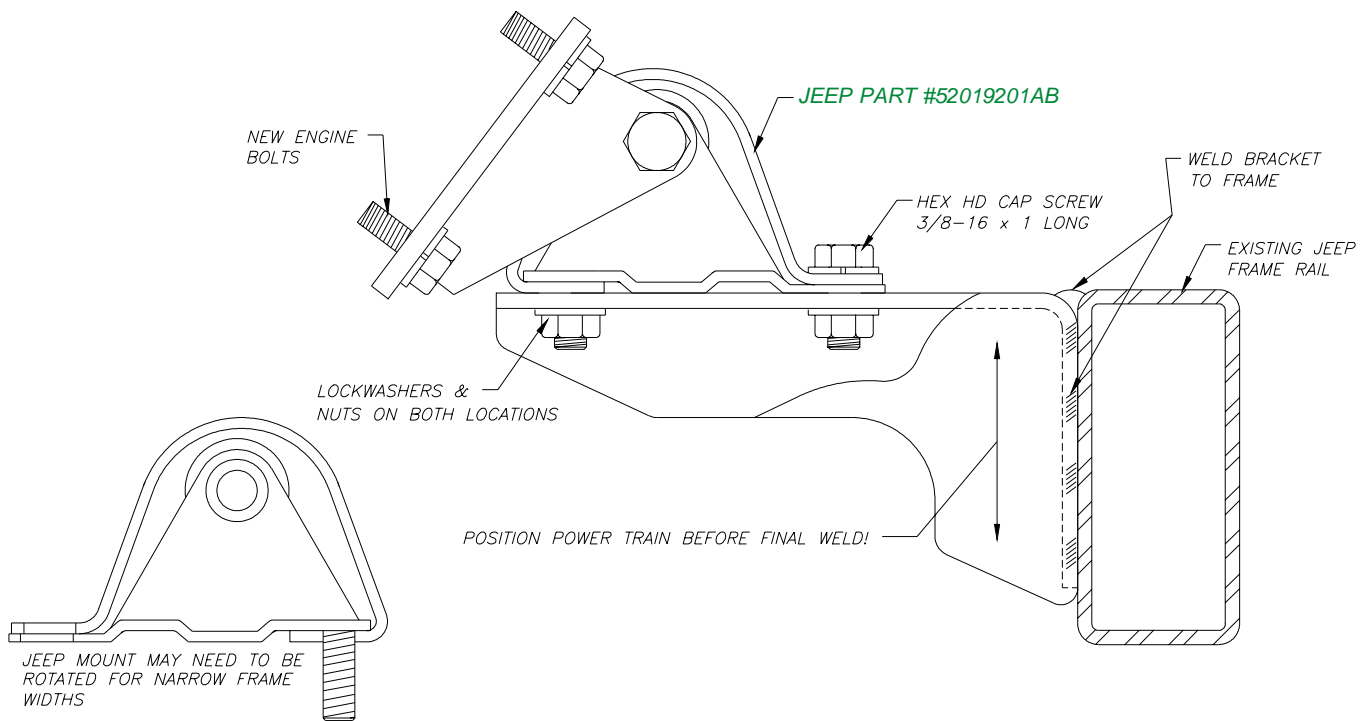

NOTE: Vehicles prior to 1980 may require shortening of the frame brackets in order to fit on inside of frame rail.