



P/N: 713002

PAGE 1 OF 1

FORD V8 ENGINE MOUNTS

KIT CONSISTS OF:

No.	Qty	Part No.	Description
1.	1	713008-B	BOLT PACK RUBBER MOUNT KIT
2.	1	713041	LONG SIDE BLOCK MOUNT
3.	1	713042	SHORT SIDE BLOCK MOUNT
4.	2	713045	FRAME BRACKETS
5.	4	716656	RUBBER MOUNT
6.	4	724303	7/16" LOCK WASHER
7.	4	724328	7/16"-14 x 1-1/4" H.H.C.S.
8.	1	BG	BUYER'S GUIDE

INSTALLATION INSTRUCTIONS:

The Universal engine mounts are designed for use on all types of 4WD and 2WD vehicles that have frame rail widths up to 28". The frame brackets can be used in either the upward or downward position for the best engine location. The brackets can be either welded or bolted into position. If you are dealing with a vehicle that has an open channel, then you should box in the frame rail prior to mounting the new bracket.

Several holes have been stamped in each motor bracket to allow the engine to be offset or centered in the frame rail. On 4WD Jeep and Toyota conversions, it is best to offset the engine 1" towards the driver's side.

The height and lateral location of the motor is determined by the placement of the frame brackets. When trial fitting the motor into the chassis assembly, the motor bracket, insulator donuts and frame brackets should be assembled. Make sure that the dual donut rubber mount assembly is properly assembled for maximum engine insulation. The final position should take into consideration the following items:

1. Firewall clearance
2. Oil pan & harmonic balancer clearance
3. Hood clearance
4. Radiator & fan allowance
5. Steering box and/or linkage clearance
6. Header/exhaust manifold clearance
7. Distributor accessibility
8. Starter motor clearance on front driveline

THE 5/8"-18 NYLON NUT SHOULD BE TORQUED TO 25 TO 30 FT./LBS.

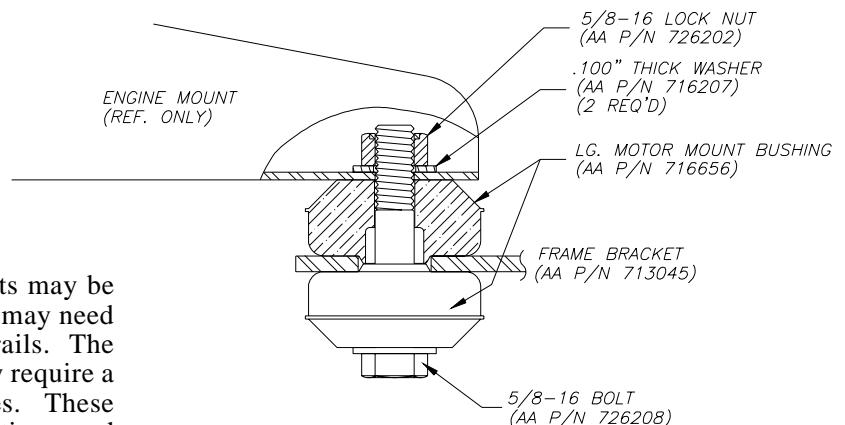

SPECIAL NOTE:

Modifications to the engine mount arm brackets may be necessary on certain installations. The mounts may need to be shortened in order to fit between frame rails. The hole location for the rubber mount position may require a new hole or slotting between two of the holes. These mounts are used on over 50 various applications and modifications as to length and hole positions are common.

SPECIAL NOTE: The components packaged in this kit have been assembled and machined for specific type of conversions. Modifications to any of the components will void any possible warranty or return privileges. If you do not fully understand modifications or changes that will be required to complete your conversion, we strongly recommend that you contact our sales department for more information. This instruction sheet is only to be used for the assembly of Advance Adapter components. We recommend that a service manual pertaining to your vehicle be obtained for specific torque values, wiring diagrams and other related equipment. These manuals are normally available at automotive dealerships and parts stores.