



ADDICTIVE DESERT DESIGNS

2015 - Current Ford F150 Venom R Front Bumper Installation Instructions

PREPARATION STEPS

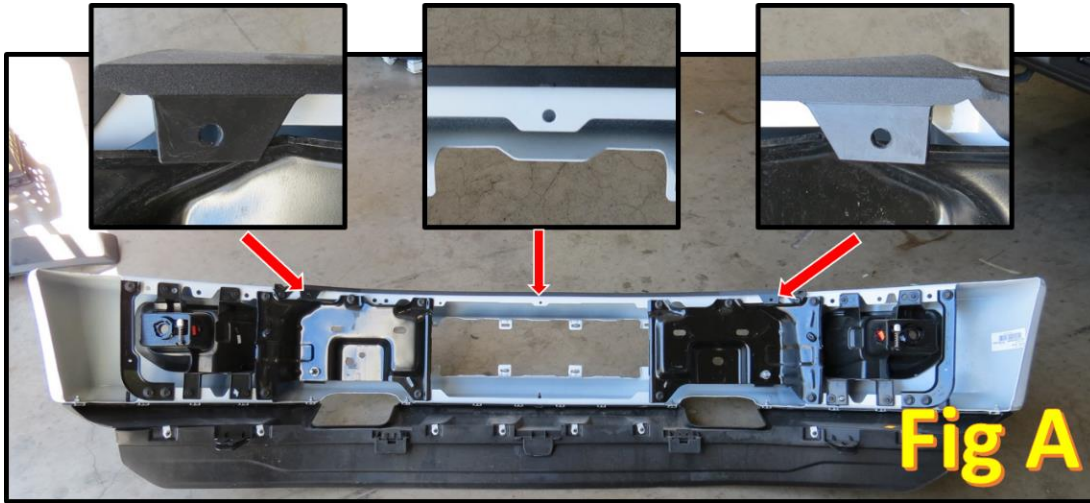
1. Disconnect the negative terminal on the battery. Park the vehicle on level ground and set the emergency brake.
2. We recommend reading through the installation instructions in whole before performing the work.
3. Estimated Installation Time: **2 Hours**
4. You will need the following tools:
 - a. 3/4" Socket and Wrench
 - b. 13/16" Socket
 - c. 15mm Socket
 - d. 7mm Socket
 - e. 5.5mm Socket
 - f. 7/32" Allen Wrench or Allen Key Socket
 - g. 9/16" Wrench or Socket
 - h. Ratchet
 - i. Utility Knife
 - j. Reciprocating Saw
 - k. 11/32" Drill Bit
 - l. Drill

Note: This installation requires 2 people for best results

5. Included in Kit:
 - 4** – Hex Head Bolt – 1/2"-13 x 1 1/2"
 - 8** – Flat Washers – 1/2"
 - 4** – Nylon Lock Nut – 1/2"-13
 - 1** – Thread Cutting Bolt – 3/8"-16
 - 1** – Flat Washer – 3/8"
 - 2** – Carriage Bolts – 3/8"-16 x 1"
 - 2** – ADD 40" Radius Light Mount Tabs

OEM REMOVAL INSTRUCTIONS

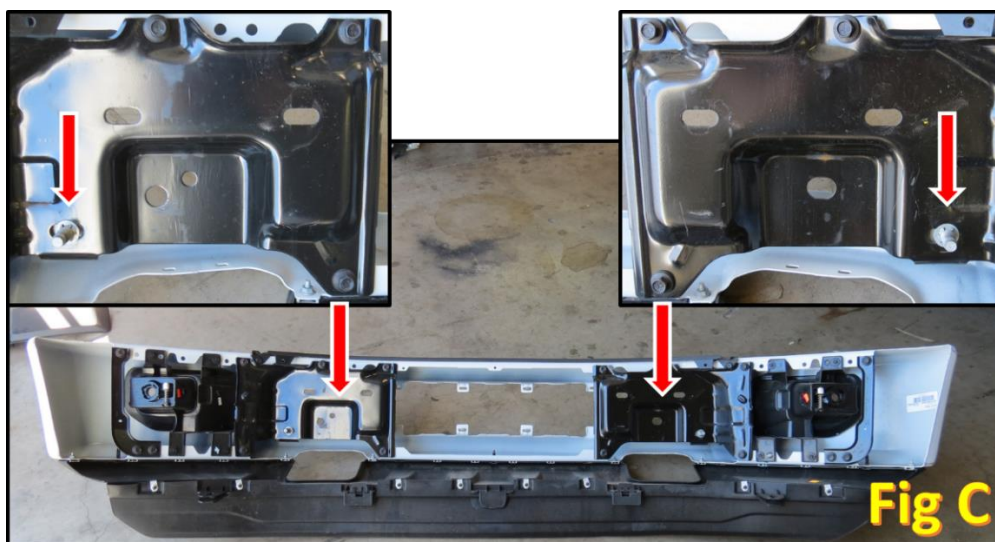
1. From the bottom of the truck, remove any fog light connectors, if your truck is equipped with fog lights, and move the wiring harness out of the way.
2. From the top, remove the 3 plastic clips that are holding the rubber shroud to the top of the front bumper. The locations of where these 3 clips attach to the front bumper have been marked in Fig A.



3. Carefully remove the front plastic piece from the bumper. There are no tools required for this, it can be pulled off by hand. (Fig B)



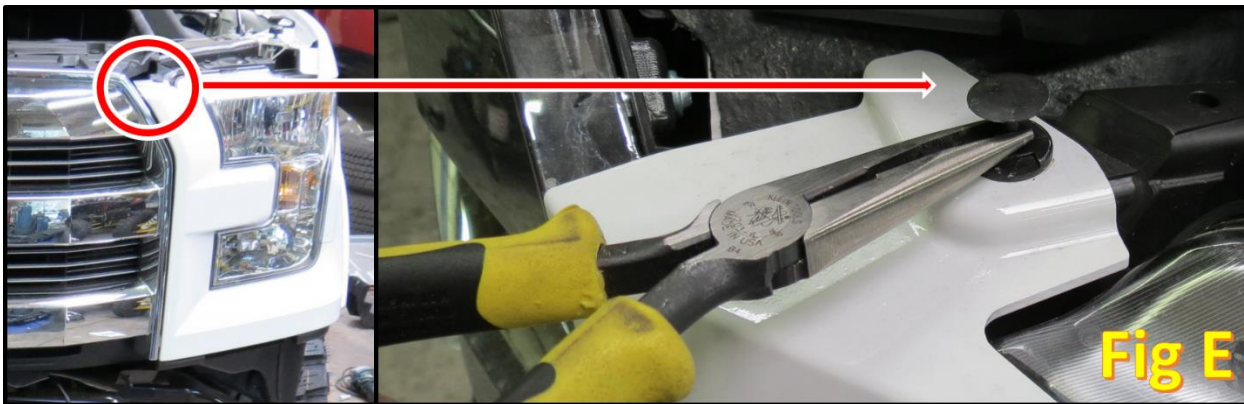
4. From the bottom, remove the 13/16" nuts (x2) holding the bumper mount to the front frame horns. There is one per side. The location of these nuts is marked in Fig C.



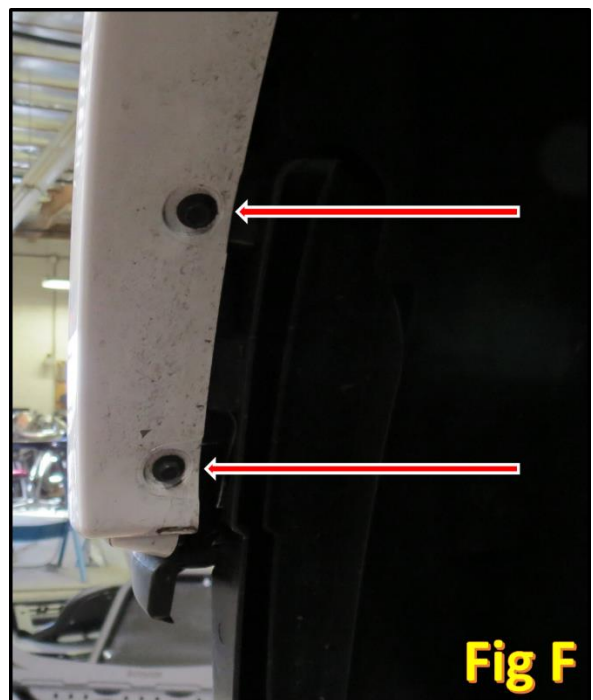
5. From the top, remove the remaining 13/16" nuts (x4) that were behind the plastic covers removed in Step 3. There are 2 per side. The location of these nuts is marked in Fig D.



6. Carefully slide the bumper out towards you and off the vehicle.
7. Remove the plastic clip on the top of the headlight bezel. Refer to Fig E.



8. Remove the two 7mm bolts farthest forward on the OEM fender flare. Refer to Fig F.
9. Gently pull the fender flare out towards you until it unclips from the headlight bezel. Refer to Fig G.



10. Gently pull the headlight bezel forward and off of the vehicle. Refer to Fig H.



11. Remove the two 5.5mm bolts on the front side of the inner fender liner that are referenced in Fig I.



12. Remove the 3 bolts referenced in Fig J on the air dam that sits behind the headlight bezel.



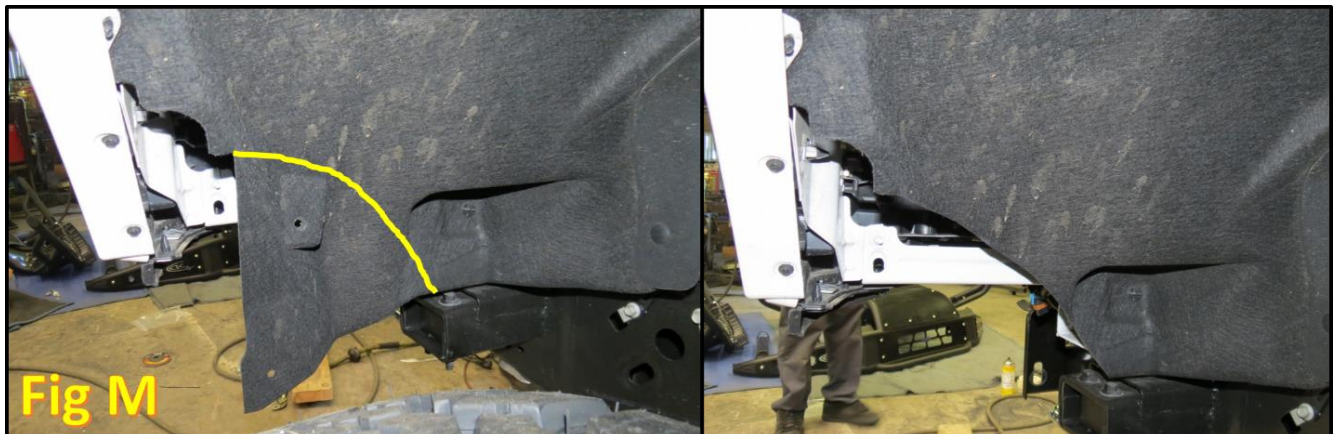
13. Undo the two clips referenced in Fig K, and pull the bottom portion of the air dam off the vehicle.



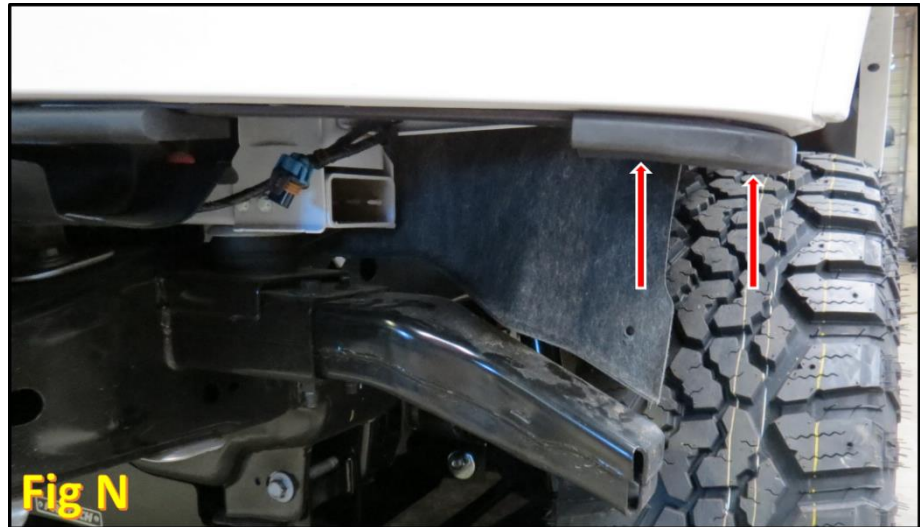
14. Push the headlight bezel back on the vehicle and reinstall the plastic clip that was removed in Step 7. Reinstall the bolts that were removed in Step 8.
15. Using a reciprocating saw, cut off the crash bar that sticks out right in front of your tires. Refer to Fig L. Make sure to paint over any bare metal to avoid rust issues.



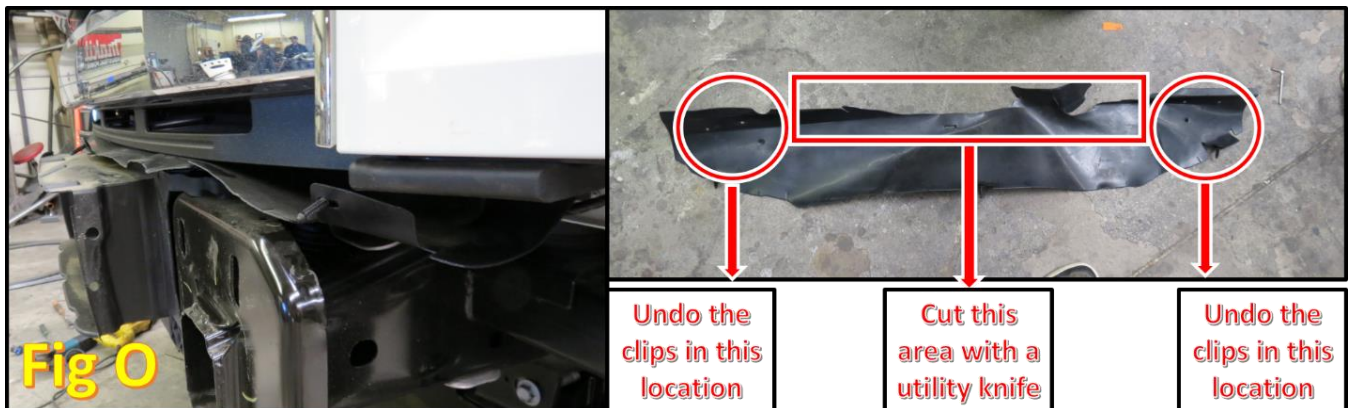
16. Using a utility knife, trim the inner fender liner that hangs down where the air dam used to be. Refer to Fig M.



17. Remove the two plastic clips that hold on the rubber piece shown in Fig N.



18. If desired, you can remove the rubber shroud that sits between the radiator and the intercooler. To do this, remove the accessible clips on the outside portions of this piece, then use a utility knife to cut it out as far back as possible. Refer to Fig O.



19. Using a reciprocating saw, cut the intercooler scoop where the molded rubber meets the plastic. (Fig P)



20. Prepare to install your new ADD Front Bumper.

INSTALLATION INSTRUCTIONS

1. If you purchased a top 40" Radius Light Bar, install that now.
 - a. Take out the two outer bolts from your upper bumper plate. Save the nuts and washers for reuse. (Fig Q)



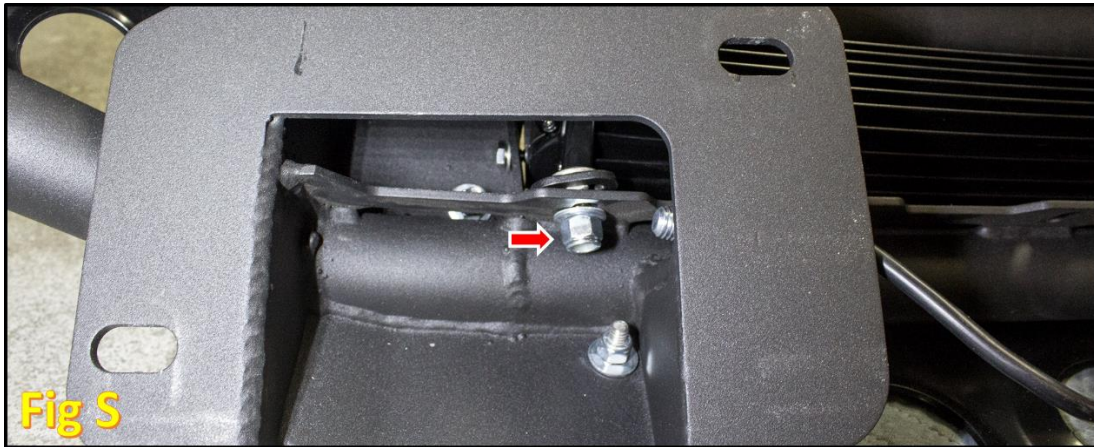
Fig Q

- b. Mount the Light Mount Tabs to your light (Leave these bolts loose for now). Then, set the supplied carriage bolts (x2) in place as shown in Fig R.

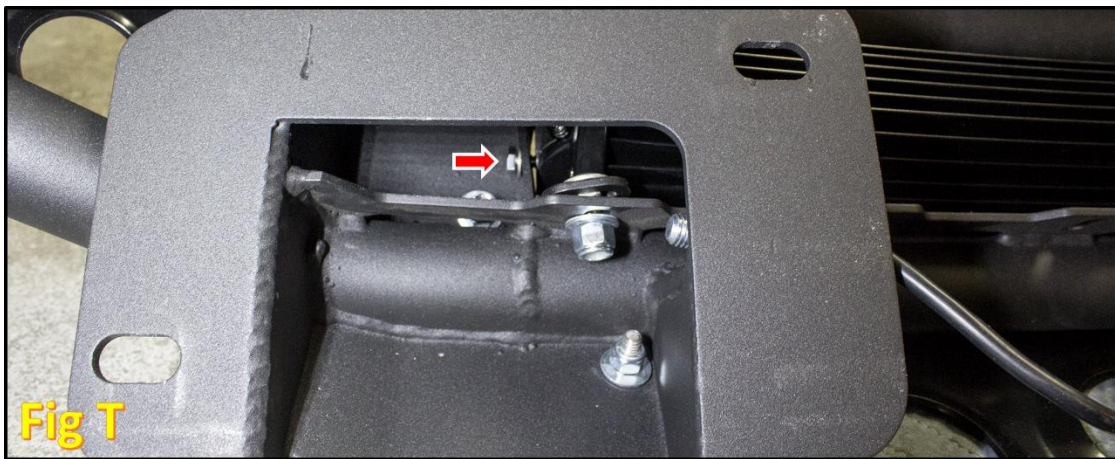


Fig R

- c. Set the light in place on top of your bumper, and reinstall the nuts and washers you removed earlier in this step. Leave these loose for now.
 - d. Set the light bar as far forward as you can to avoid any clearance issues with the grille when you mount the bumper, then tighten the 2 bracket mounting nuts to 20 foot pounds.
 - e. Tilt the light whichever way you would like it to face, then tighten the light mounting bolts to the light manufacturer's torque specification.
2. If you purchased a Light Mount Kit and a 30" Radius Light Bar to mount in your bumper, install that now.
 - a. Loosely mount your light bar to the two light mounts. Set the two carriage bolts (Supplied with the Light Mount Kit) in place the same way you did with the 40" Radius Bar.
 - b. Set the light bar in place. It should drop in easily from the back side of the bumper.
 - c. Install the two nuts and washers (Supplied with the Light Mount Kit). Line the light bar up how you want it, then tighten these two nuts to 20 foot pounds. (Fig S)



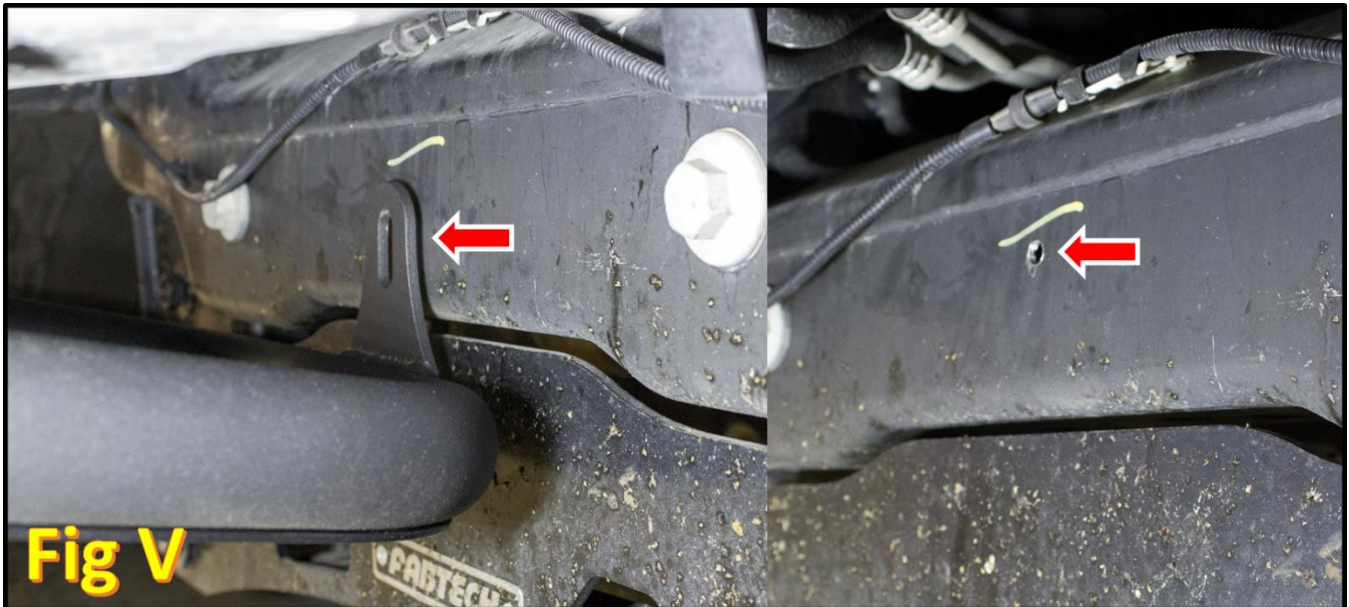
- d. Set the tilt of your light bar, then tighten the light mount bolts to the light manufacturer's torque specifications. (Fig T)



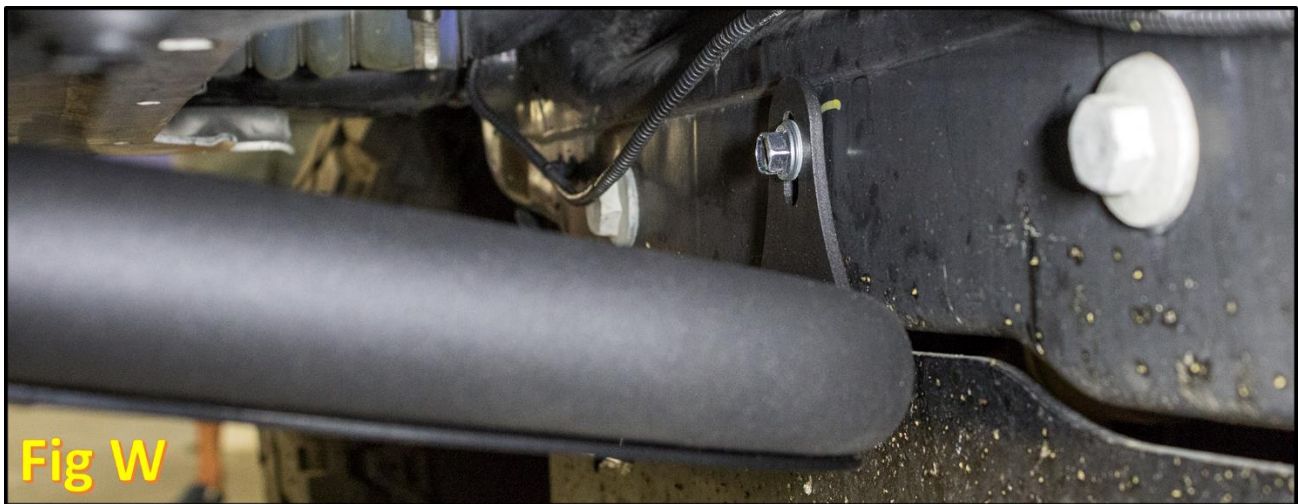
3. Mount your ADD bumper to your truck.
 - a. Line up the holes on the mounting tabs of the ADD Bumper with the mounting holes on the frame horns of the truck. Use the supplied 1/2 x 1 1/2" bolts (x4), 1/2" Washers (x8), and 1/2" locking nuts (x4) to hold the bumper in place. Install them finger tight for now. If you have lights in the center section of your bumper, you will have to set the upper/inner two mounting bolts in place on the bumper prior to putting it on the vehicle. (Fig U)



- b. Align your bumper so it sits straight in relation to the grille/valance, then tighten at least two of the mounting bolts to 70 foot pounds. Mark the location of the lower mount hole on your cross member using a sharpie or paint marker. Then remove your bumper and drill a hole in the marked area with an 11/32" Drill Bit. (Fig V)



- c. Remount your bumper to your truck the same way you did earlier in this step. Then, once all the 1/2" bolts are loosely installed, loosely install the supplied 3/8" Thread Cutting Bolt and 3/8" Washer into your newly drilled hole. (Fig W)



- d. Line up the bumper so that it sits straight in relation to the grille/valance. Go back and torque the 1/2" Mounting Bolts to 70 foot pounds. Torque the 3/8" Thread Cutting Bolt to 20 foot pounds. Use the dimple dies in the skid plate to gain access to your upper/inner mounting bolts. (Fig X)



4. Follow your light manufacturer's installation guides for any wiring information.
5. Stand back and enjoy your ADD Venom R Front Bumper.
6. Check and re-tighten if needed, all mounting bolts after 100 miles and periodically thereafter.



Looking for dependable off-road bumpers? Rely on Addictive Desert Designs for quality and long-lasting products.