

Preparation:

- Disconnect the negative battery terminal. Park the vehicle on level ground and set the emergency brake.
- We recommend reading through the installation instructions in whole before performing the work.
- Estimated Installation Time: **6 Hours**

*****This installation requires 2 people for best results*****

You will need the following tools:

- Ratchet
- 7/32" Allen Wrench/Socket
- 13mm Socket
- Wire Crimpers
- 5/16" Allen Wrench/Socket
- 9/16" Wrench
- Drill
- 3/4" Wrench
- 1/2" Socket
- 1/2" Drill Bit

Included in Kit:

Main Rack

Description	Quantity
M8-1.25 x 30mm Hex Head Bolt (Black)	4
M8 Washers (Black)	4
3/8" Button Head Bolts (Black)	8
3/8" Washers (Black)	8
3/8" Lock Nuts (Black)	8
1/2" Button Head Bolts (Black)	6
1/2" Washers (Black)	6
1/2" Lock Nuts (Black)	6
HoneyBadger Rack Wiring Harness (Lower)	1
Chase Rack Bed Rail Support Brackets	2
Chase Rack Side Pieces	2
Chase Rack Center Piece	1

Tire Carrier

Description	Quantity
3/8" Button Head Bolts	14
3/8" Washers	26
3/8" Lock Nuts	10
3/8" U-Nuts	4
Spare Tire Spinner	1
Tire Carrier Arms	2
Tire Carrier Center Piece	1

Roof Rack

Description	Quantity
3/8" Button Head Bolts (Black)	106
3/8" Washers (Black)	106
3/8" Nylon Lock Nuts (Black)	106
Black Threaded Rubber Bumpers	2
5/16" Washers	2
5/16" Lock Nuts	2
1/4" Washers (Black)	6
HoneyBadger Rack Harness (Upper)	1
Roof Rack Nose Piece	1
Roof Rack Front Cross Member	1
Roof Rack Center Cross Member	1
Roof Rack Rear Cross Member	1
Roof Rack Rear Piece	1
Roof Rack Front Reinforcement Bracket	1
Roof Rack 40" Light Mounts	2
Roof Rack Rubber Bumper Mounting Brackets	2
Roof Rack Center Support Plate	1

Main Rack Assembly:

1. Find one of the Chase Rack Side Pieces and the Chase Rack Center Section. Set these two pieces together, then use the supplied 3/8" x 1" Button Head Bolts (x4), 3/8" Washers (x4), and 3/8" Lock Nuts (x4) to hold them together. Leave these bolts loose for now. (Fig A)



Fig A

2. Repeat Step 1 with the other Chase Rack Side Piece. Once all bolts are installed, go back and torque the 3/8" Bolts to 30 foot pounds. (Fig B)



Fig B

3. Mount your SR-Q Flush Mount Light to the Chase Rack Center Section. Use the mounting hardware supplied with your light. (Fig C)



Roof Rack Assembly:

4. Find the Roof Rack Front Piece. Find the single reinforcement bracket that gets bolted to the bottom of it and set it in place. Secure it to the front piece using the supplied 3/8" Bolts (x4), 3/8" Washers (x4), and 3/8" Lock Nuts (x4). (Fig D)

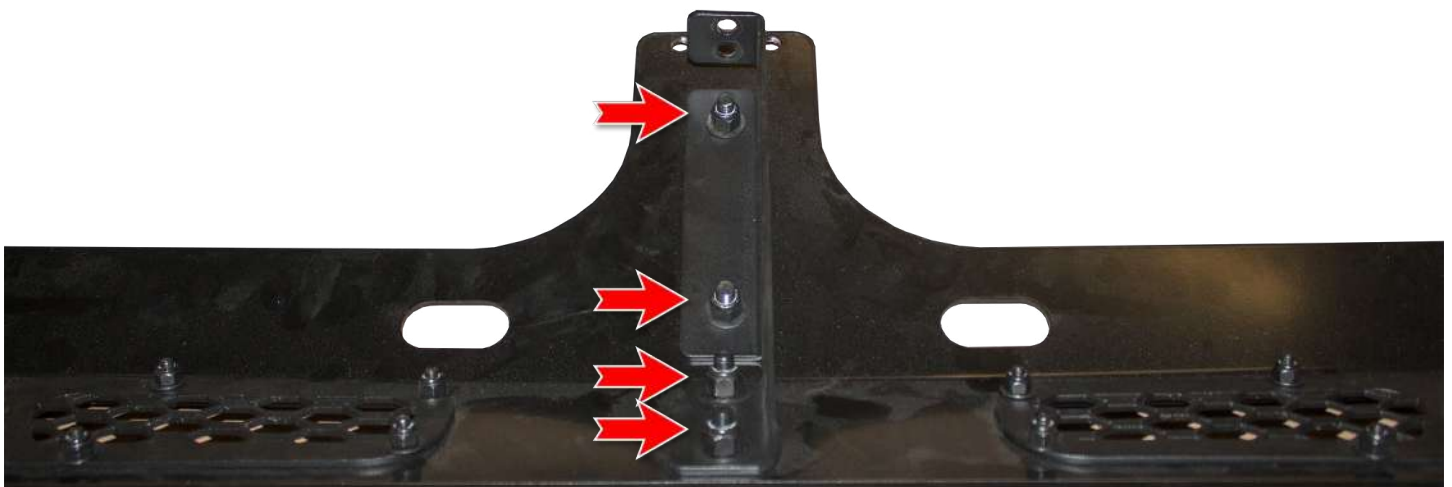

Fig D

5. Find the Roof Rack Front Piece, one of the Roof Rack Side Pieces, and the Front Light Mount (either for a single 40" Light). Set them together, with the Side Piece laying underneath the Front Piece and the Light Mount on top of the Front Piece. Then, use the supplied 3/8" x 1" Button Head Bolts (x6), 3/8" Washers (x6), and 3/8" Lock Nuts (x6) to hold the pieces together. Leave these bolts loose for now. (Fig E)



Fig E

6. Repeat Step 5 with other Roof Rack Side Piece. Leave these bolts loose for now.
7. Put the Front Cross Member in place. The Front Cross Member is the one with 4 holes in the top/center. Once the cross member is in place, secure it with the supplied 3/8" Bolts (x14), 3/8" Washers (x14), and 3/8" Lock Nuts (x14). There are 5 bolts on each side (2 holes stay empty for now) and 4 bolts in the center. (Fig G)

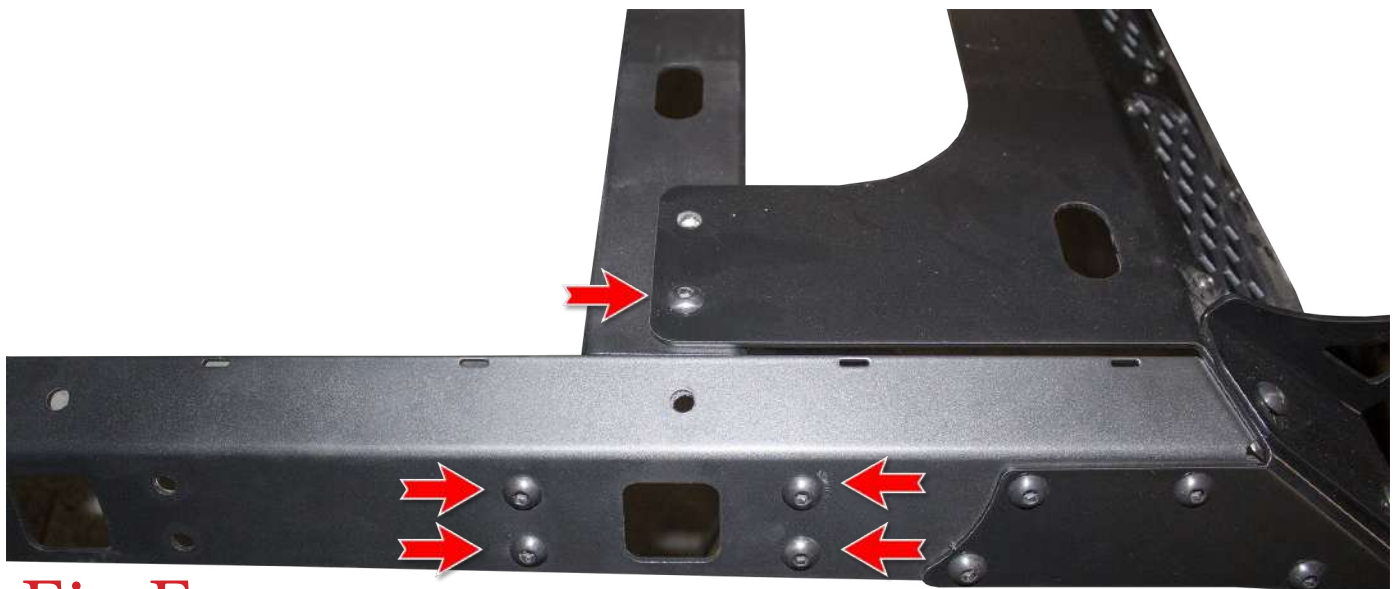

Fig F

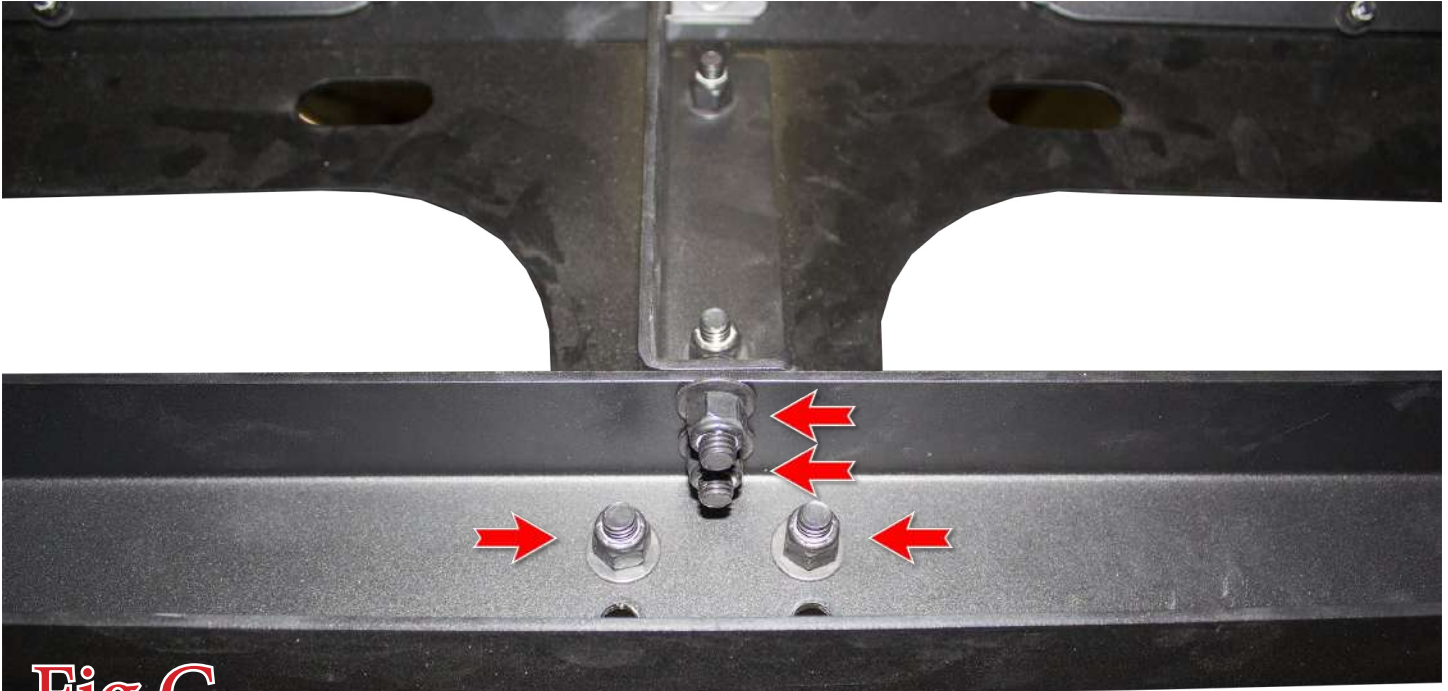

Fig G

8. Find the supplied Rubber Bumpers (x2), 5/16" Washers (x2) and 5/16" Lock Nuts (x2). Install the Rubber Bumpers to the Rubber Bumper Mounting Brackets as shown in (Fig H).



Fig H

9. Set the rubber bumpers in place on the roof rack (uses the remaining two empty holes from Step 7). Use the supplied 3/8" Bolts (2 per side), 3/8" Washers (2 per side) and 3/8" Lock Nuts (2 per side) to secure the bumper plates to the roof rack. (Fig I)

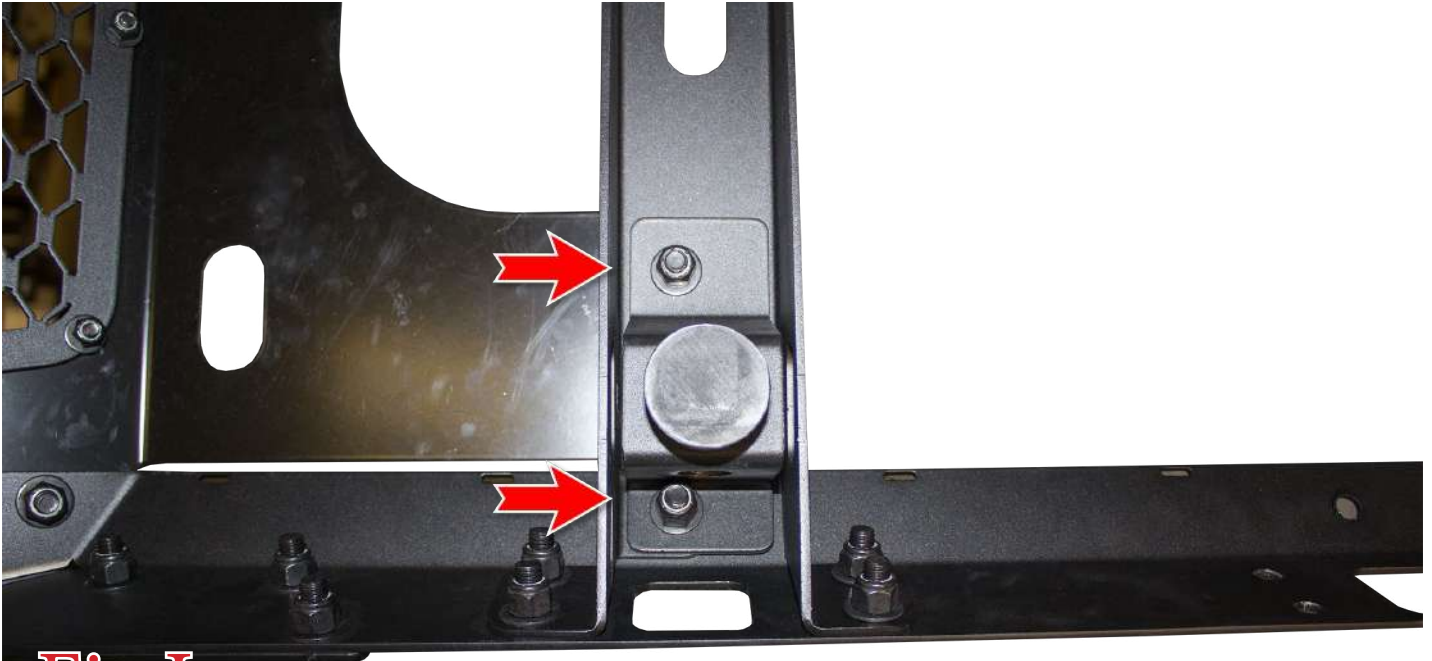

Fig I

10. Set the Middle Cross Member in place on the Roof Rack. The Middle Cross Member is the one with one set of centered holes on top section. Secure the cross member to the rack with the supplied 3/8" Bolts (x10), 3/8" Washers (x10), and 3/8" Lock Nuts (x10). (Fig J)

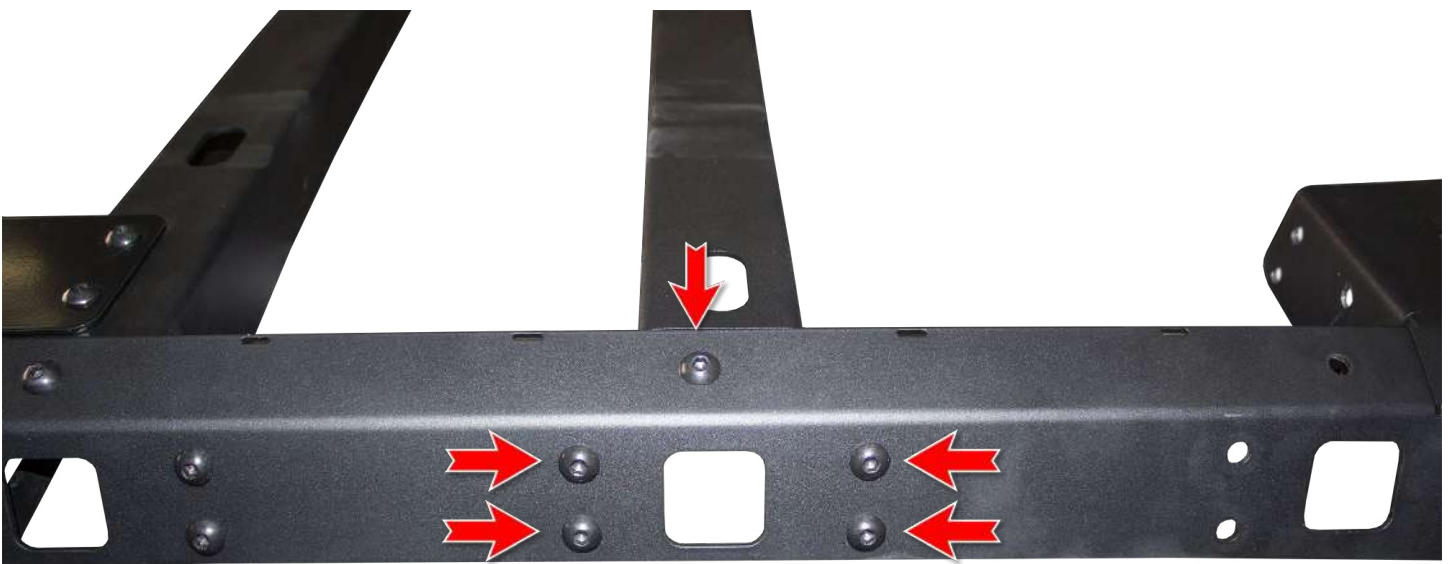

Fig J

11. Set the Rear Cross Member in place. Set it so the half circle cutout faces the rear of the Roof Rack. Then, secure the cross member using the supplied 3/8" Bolts (x18), 3/8" Washers (x18), and 3/8" Lock Nuts (x18). (Fig K)

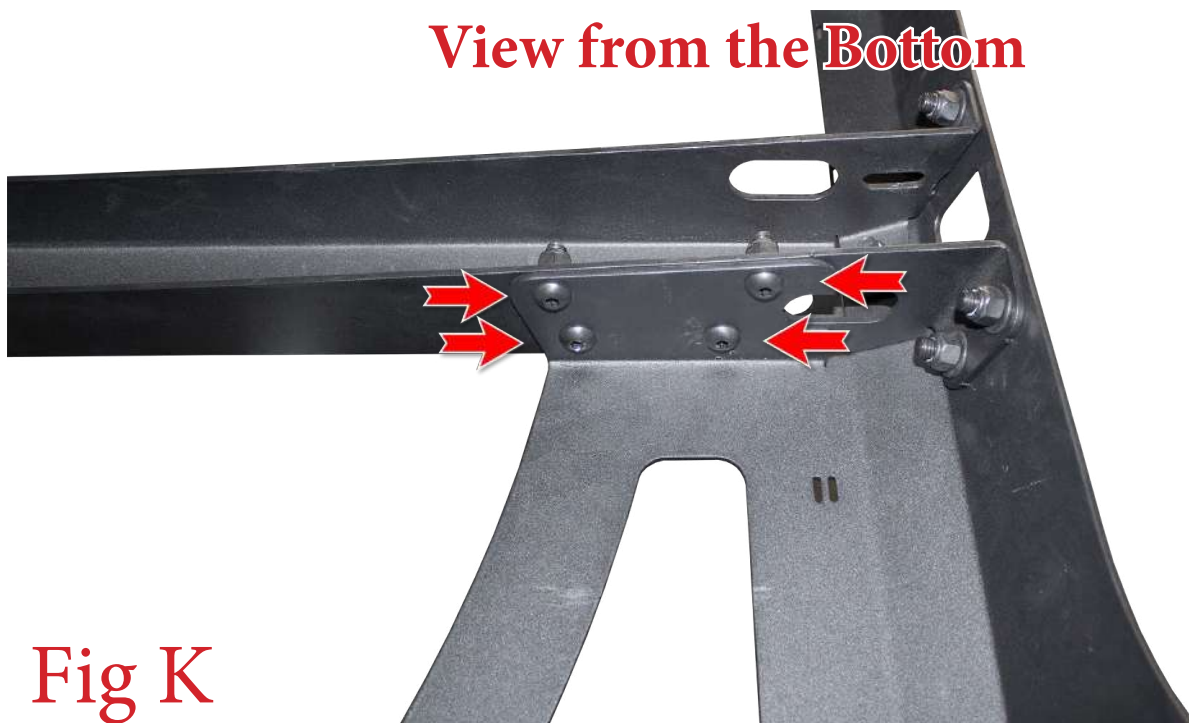

Fig K



12. Put the Center Support Plate in place. Then, secure it to the Roof Rack using the supplied 3/8" Bolts (x6), 3/8" Washers (x6), and 3/8" Lock Nuts (x6). (Fig L)



Fig L

13. Find the Roof Rack Rear Piece and set it in place. Secure it to the Roof Rack using the supplied 3/8" Bolts (x16), 3/8" Washers (x16), and 3/8" Lock Nuts (x16). (Fig M, Fig N, & Fig O)

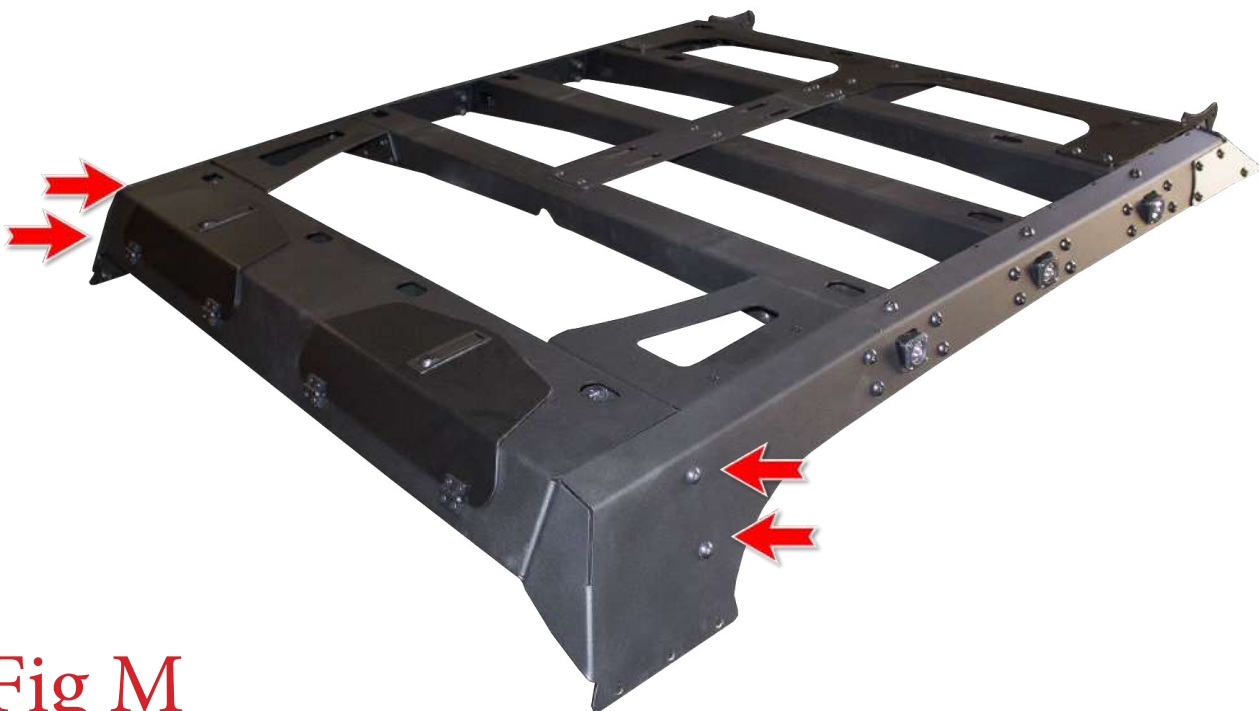

Fig M

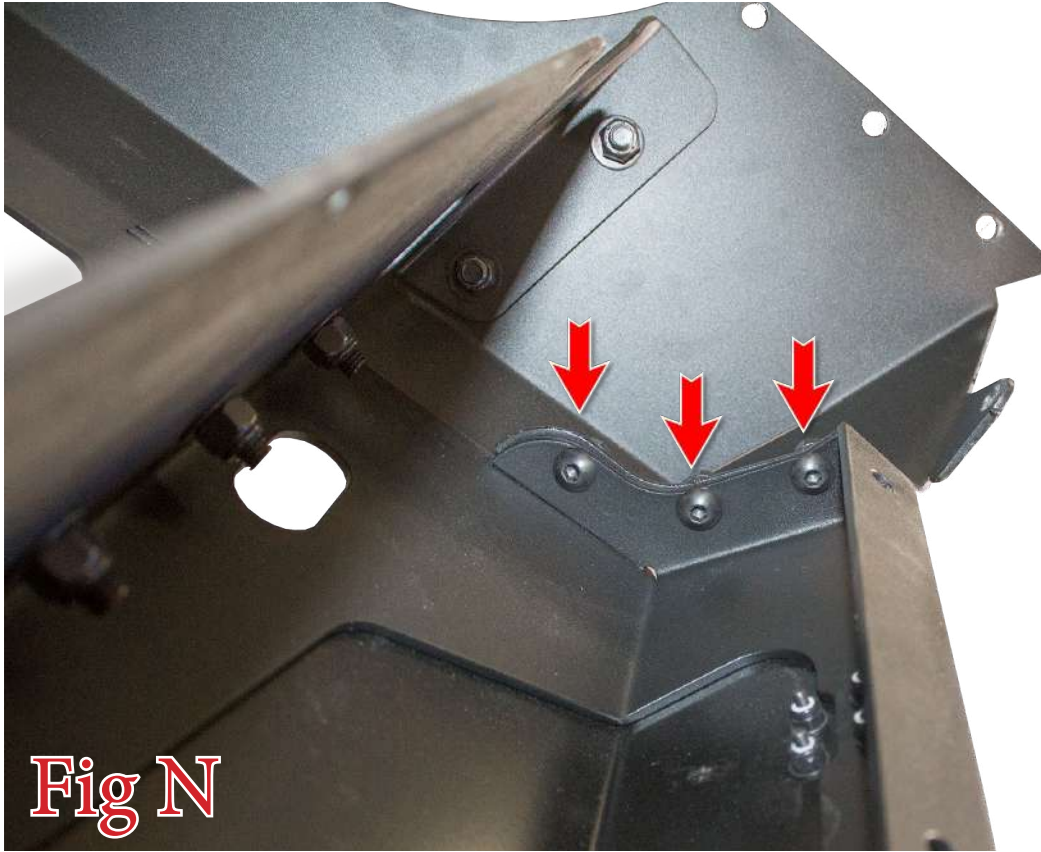

Fig N

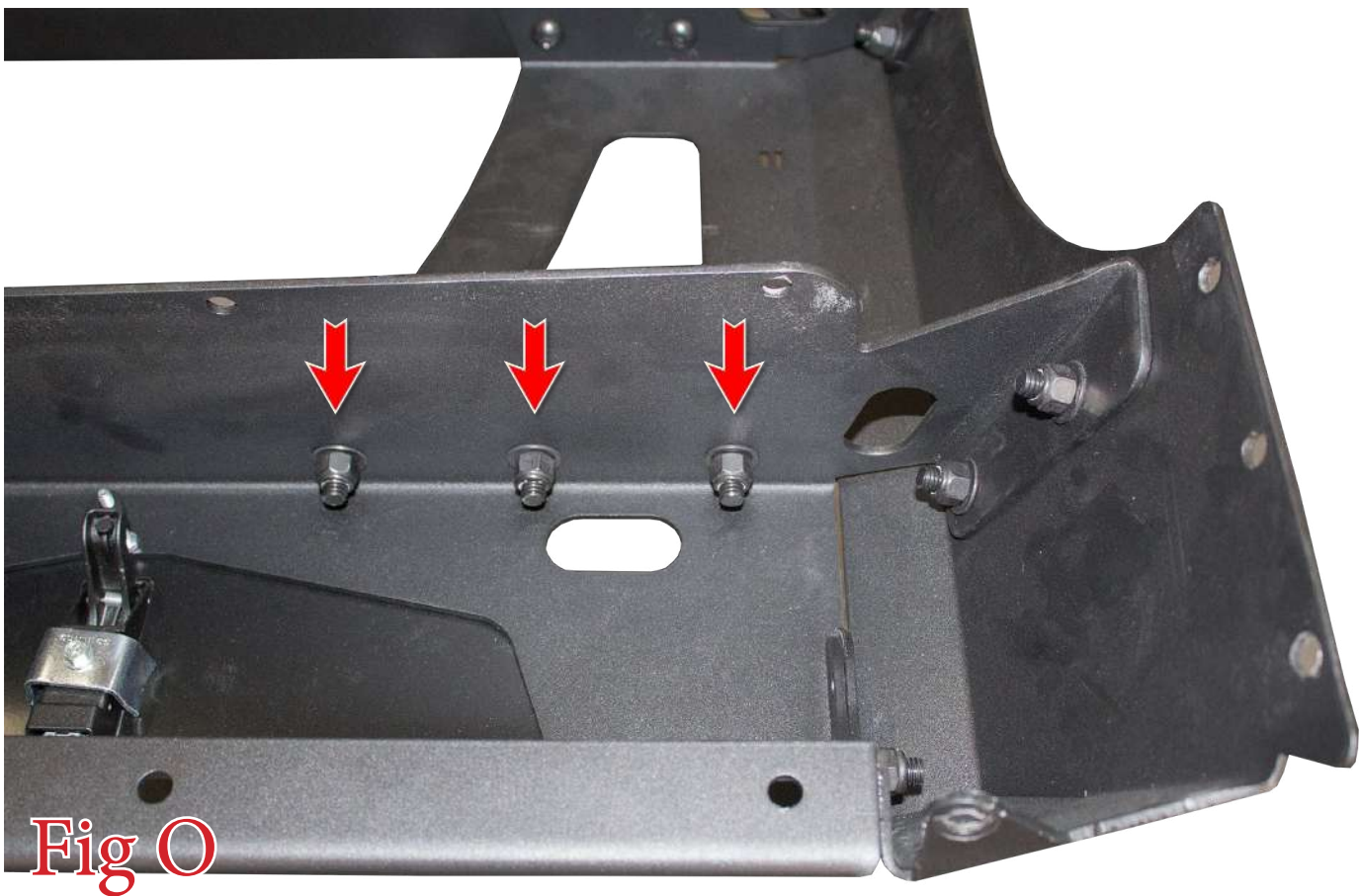

Fig O

14. Install any lights you have onto your roof rack now. Use the light manufacturer's mounting hardware for the front 40" Light. Then, use the manufacturer's hardware plus the supplied 1/4" Black Washers (x6) for the Side Lights. (Fig P)



Roof Rack Installation:

15. While the Main Rack is still off the vehicle, put the Roof Rack in place onto the main rack. Use the supplied 3/8" Bolts (x22), 3/8" Washers (x22), and 3/8" Nuts (x22) to secure the roof rack to the main rack. There are 7 bolts on the front plate of the main rack (Fig Q). There are 7 bolts inside the tool box portion (Fig R). There are 8 bolts on the outside corners of the roof rack (Fig S).



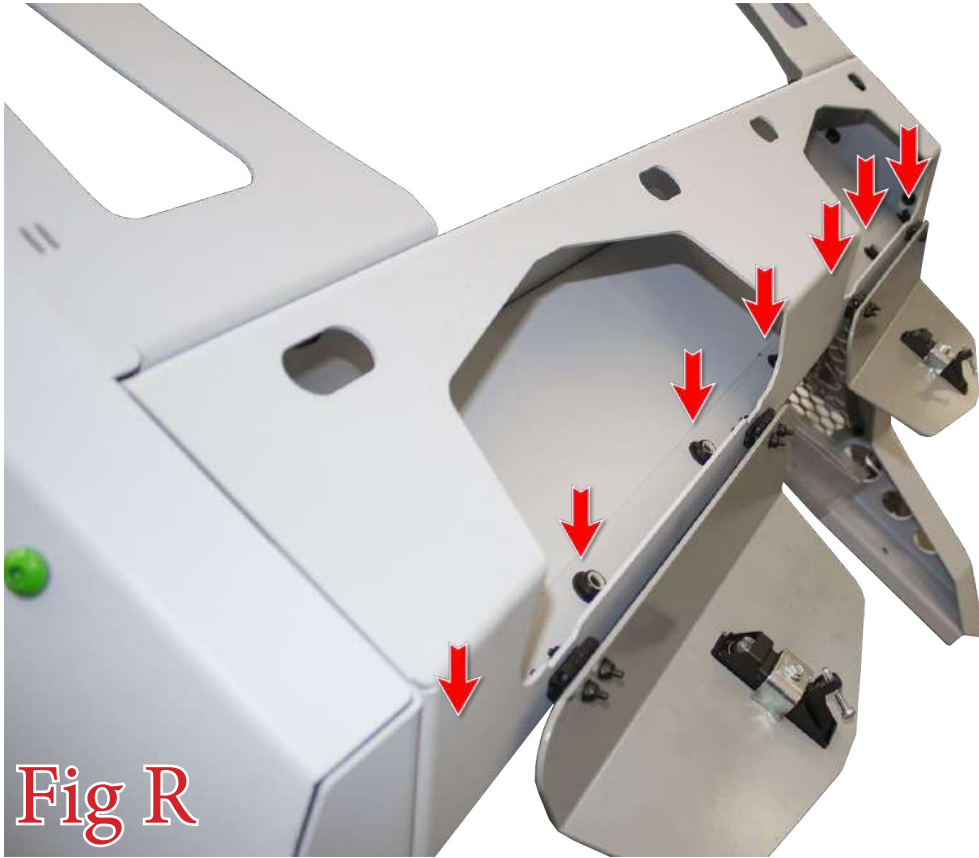

Fig R



Fig S

Main Rack Installation:

16. Use the supplied M8 Bolts (x2) to attach the Chase Rack Mounting Plate to the truck bed as shown in (Fig T). Then, repeat this step on the other side of the truck bed.



17. Using a Drill and a 1/2" Drill Bit, drill the three mounting holes (per side) through the bed rail from the bottom side. Use the Chase Rack Mounting Plate as your template to drill the holes. (Fig U) Then, repeat this step on the other side of the truck bed.

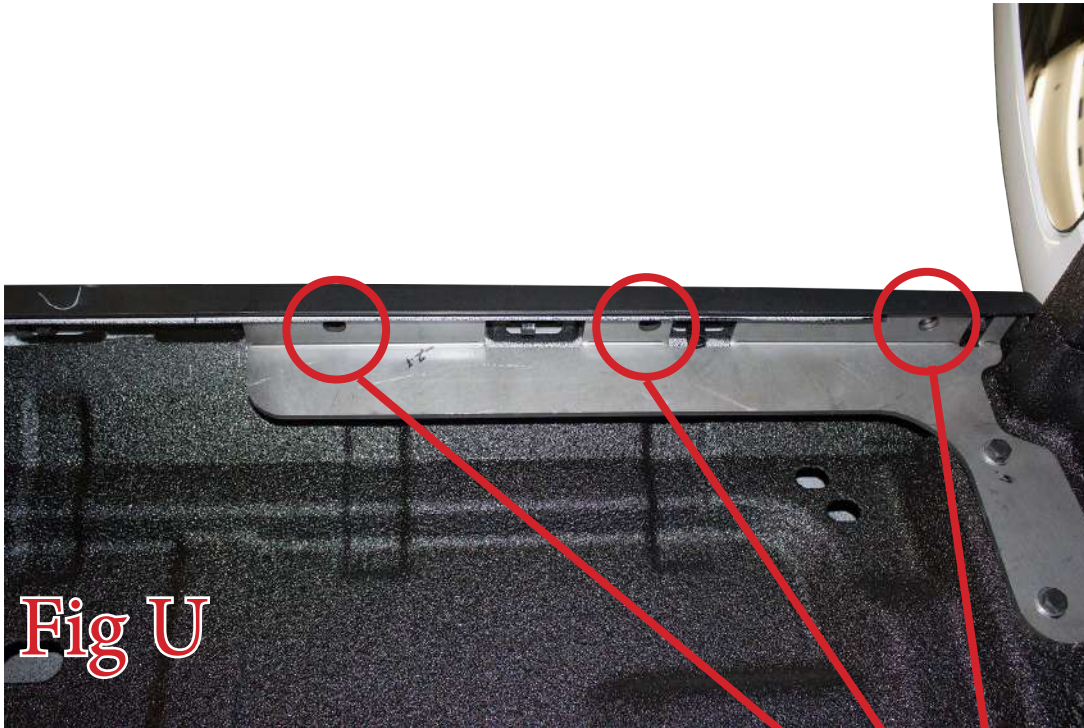

18. If you have any lights to install on your chase rack, now is a good time to do so. Use the hardware supplied by the light manufacturer to mount your light to your chase rack.

19. IF YOU ARE INSTALLING A TIRE CARRIER WITH YOUR CHASE RACK, SKIP THIS STEP** Set the Chase Rack/Roof Rack in place on the vehicle, lining the mounting holes on the rack up with the holes you drilled in Step 17. Use the supplied 1/2" Bolts (x6), 1/2" Washers (x6), and 1/2" Lock Nuts (x6) to secure the rack to the vehicle. Once all bolts are loosely installed, torque the 1/2" Bolts to 70 foot pounds. (Fig V)

Fig V

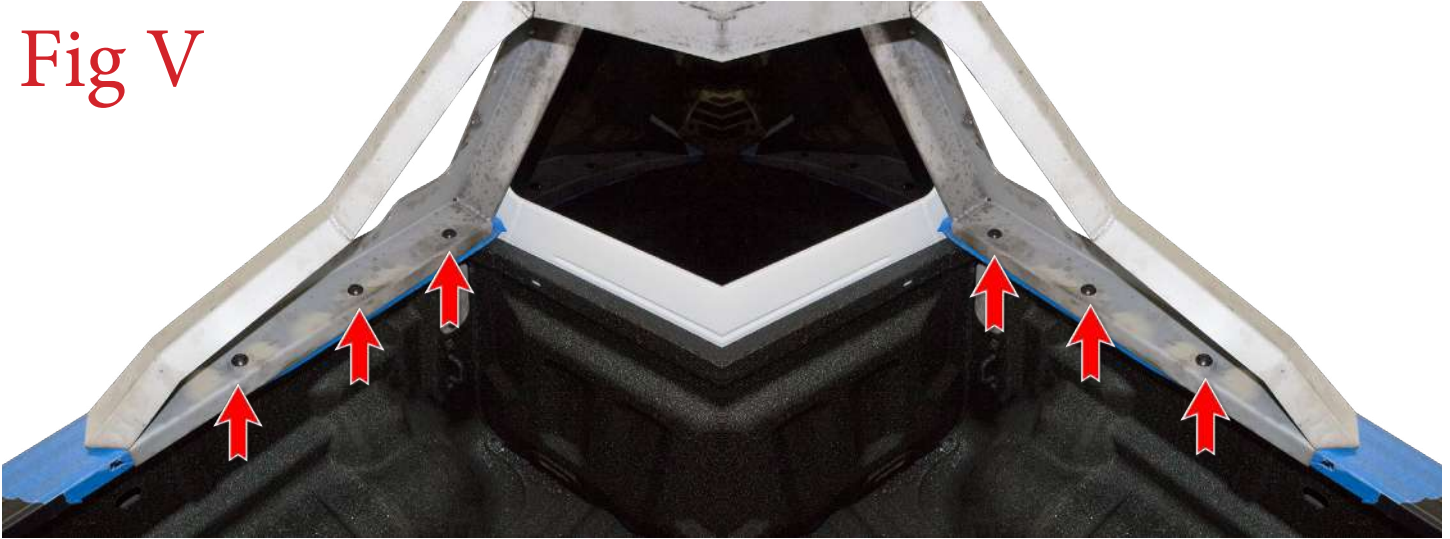

Tire Gate Installation:

20. Set the Chase Rack/Roof Rack in place on the vehicle, lining the mounting holes on the rack up with the holes you drilled in Step 17. Then, set the Tire Carrier Arms in place, lining the mounting holes up with Chase Rack mounting holes. With both pieces in place, install the supplied 1/2" Bolts (x6), 1/2" Washers (x6), and 1/2" Lock Nuts (x6). Once all bolts are loosely installed, torque the 1/2" Bolts to 70 foot pounds.

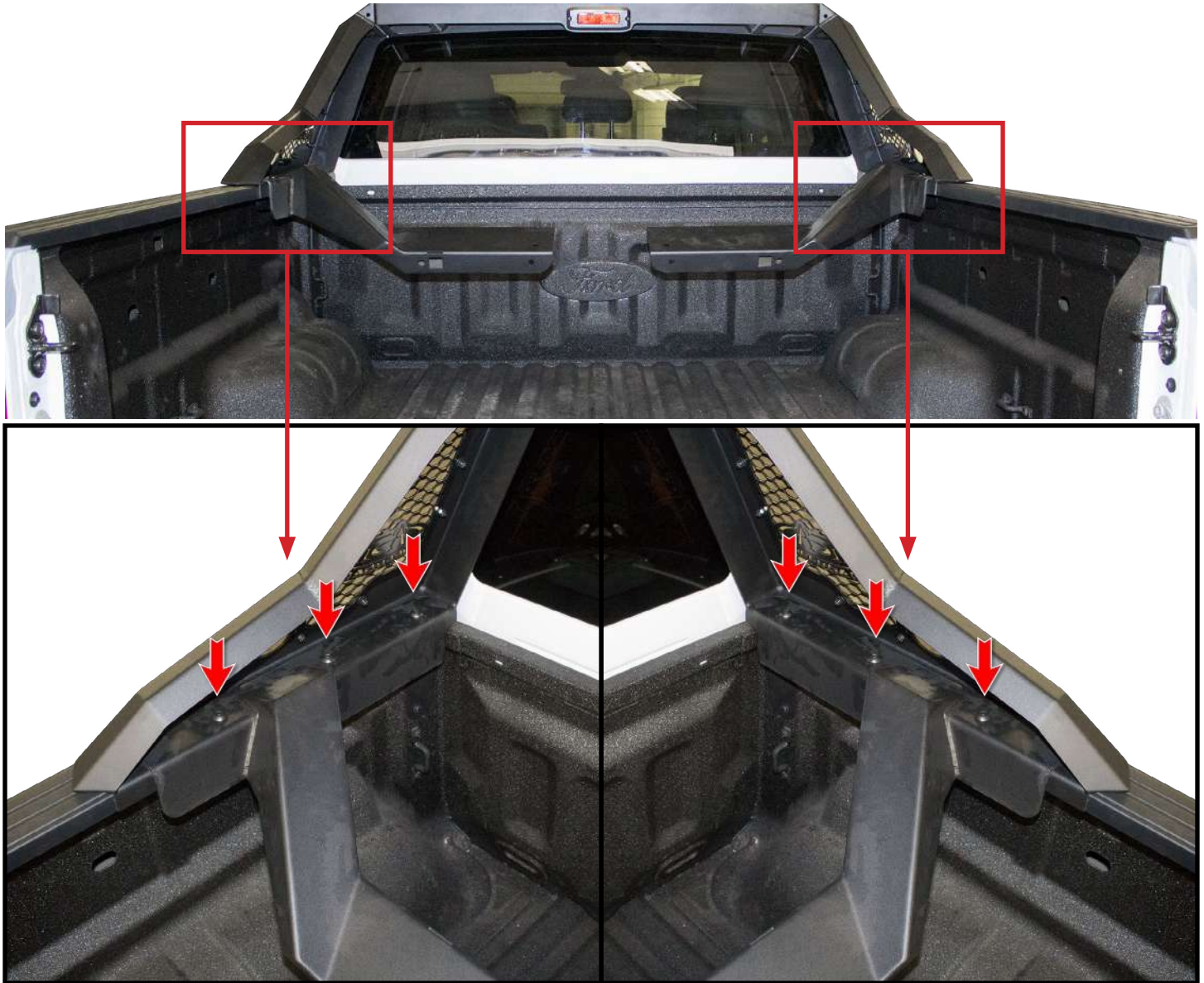

21. Set the supplied 3/8" U-Nuts (2 per arm) in place on the tire carrier arms. (Fig W)



Fig W

22. Set the Tire Carrier Center Piece in place on the two arms. Then, go back and install the supplied 3/8" Bolts (x4) and 3/8" Washers (x4) into the U-Nuts you installed in Step 21. (Fig X)

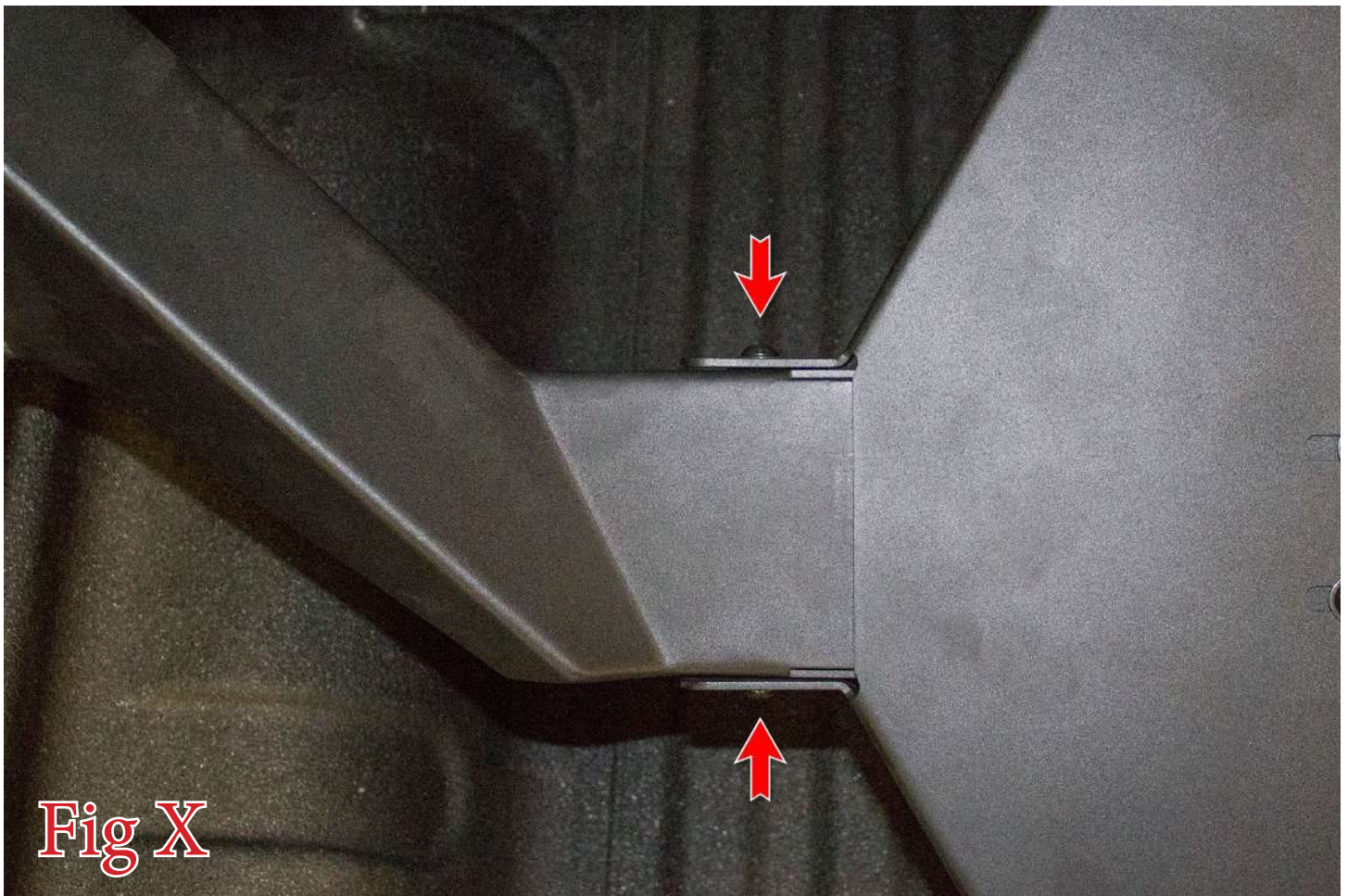
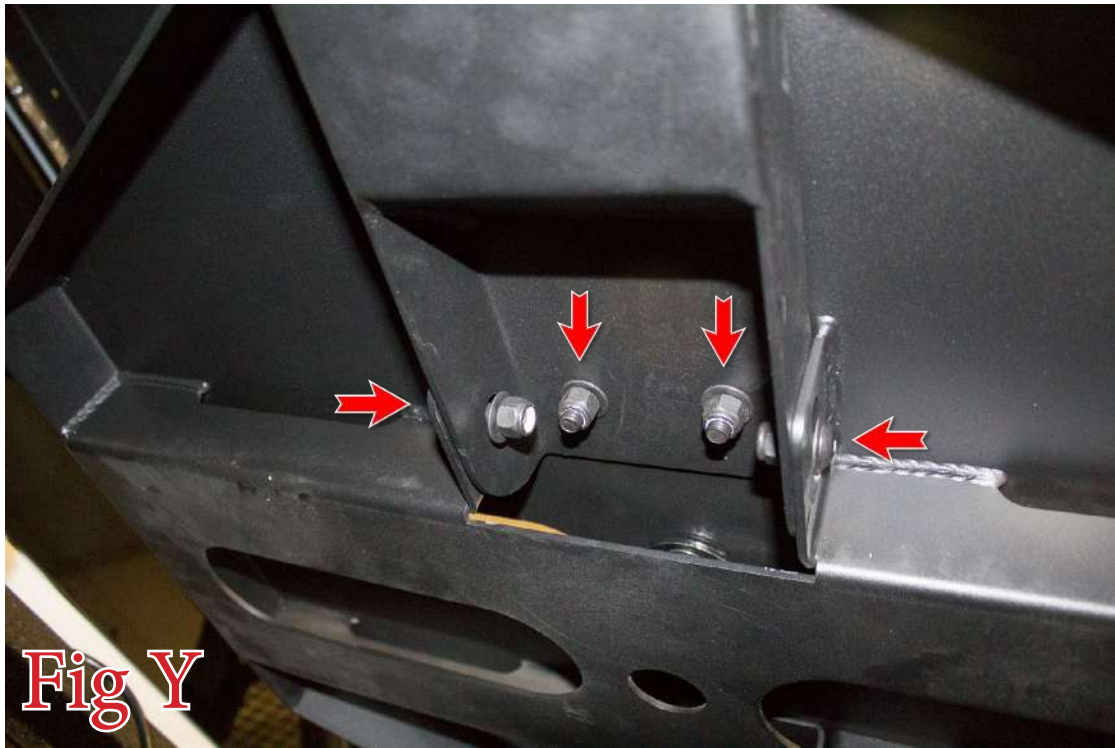
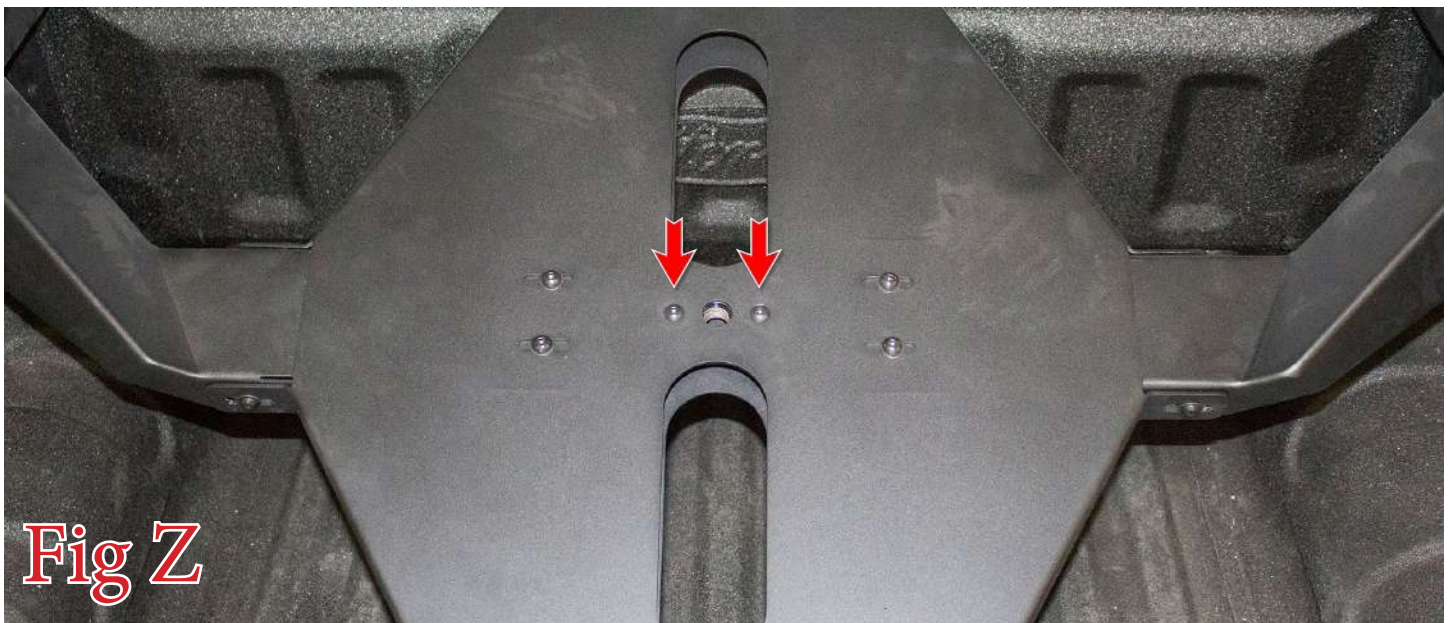

Fig X

23. Install the supplied 3/8" Bolts (x8), 3/8" Washers (x16), and 3/8" Lock Nuts (x8) into the remaining mounting holes for the Tire Carrier Center Piece. (Fig Y)



24. Set the lower portion of the Spare Tire Spinner in place. Then, secure it using the supplied 3/8" Bolts (x2), 3/8" Washers (x2), and 3/8" Lock Nuts (x2). (Fig Z)



25. Put your spare tire in place and install the top portion of the Spare Tire Spinner as shown in (Fig AA).



Wiring:

26. There is an upper and a lower portion of the HoneyBadger Chase Rack Wiring Harness. The upper portion is the shorter portion. Run this through your roof rack as shown in (Fig AB). Line it up so the blunt cut wires at the end line up with the 40" Light wiring and the connectors line up with your Rigid Ignite lights. Pass the middle section through the toolbox portion of the roof rack. Have the two connectors sit inside the toolbox portion of the roof rack, on the driver side of the vehicle. (Fig AC)

Have the blunt cut wires line up with the 40" Light Wiring.

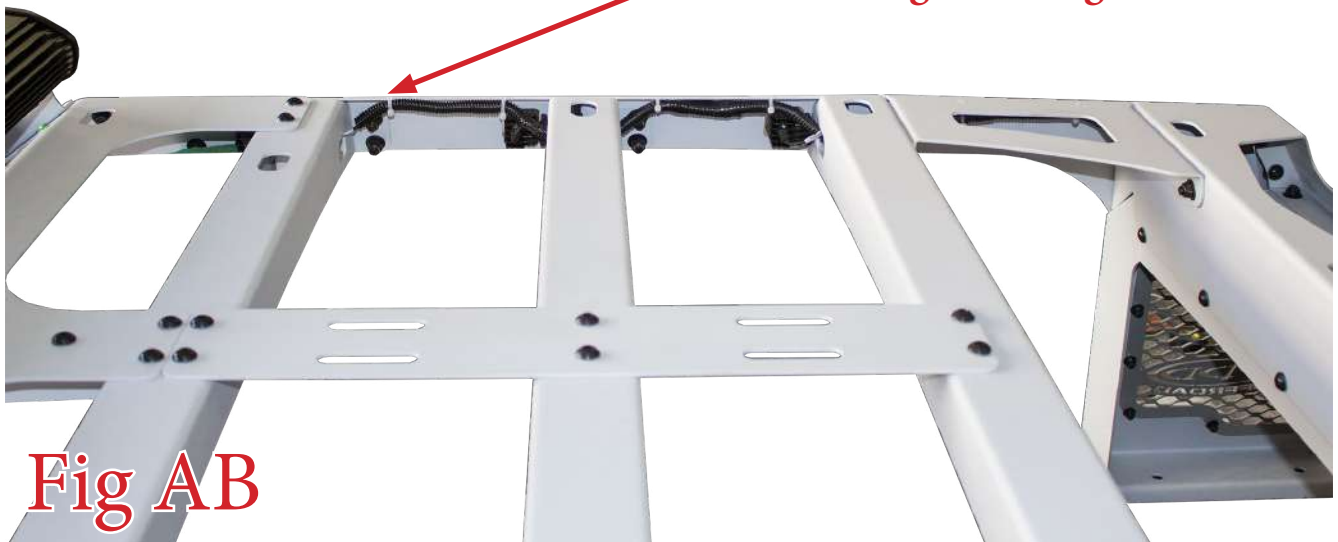

Have the connectors sit in the toolbox portion of the roof rack on the driver side.

Pass the center section of the harness through the toolbox.

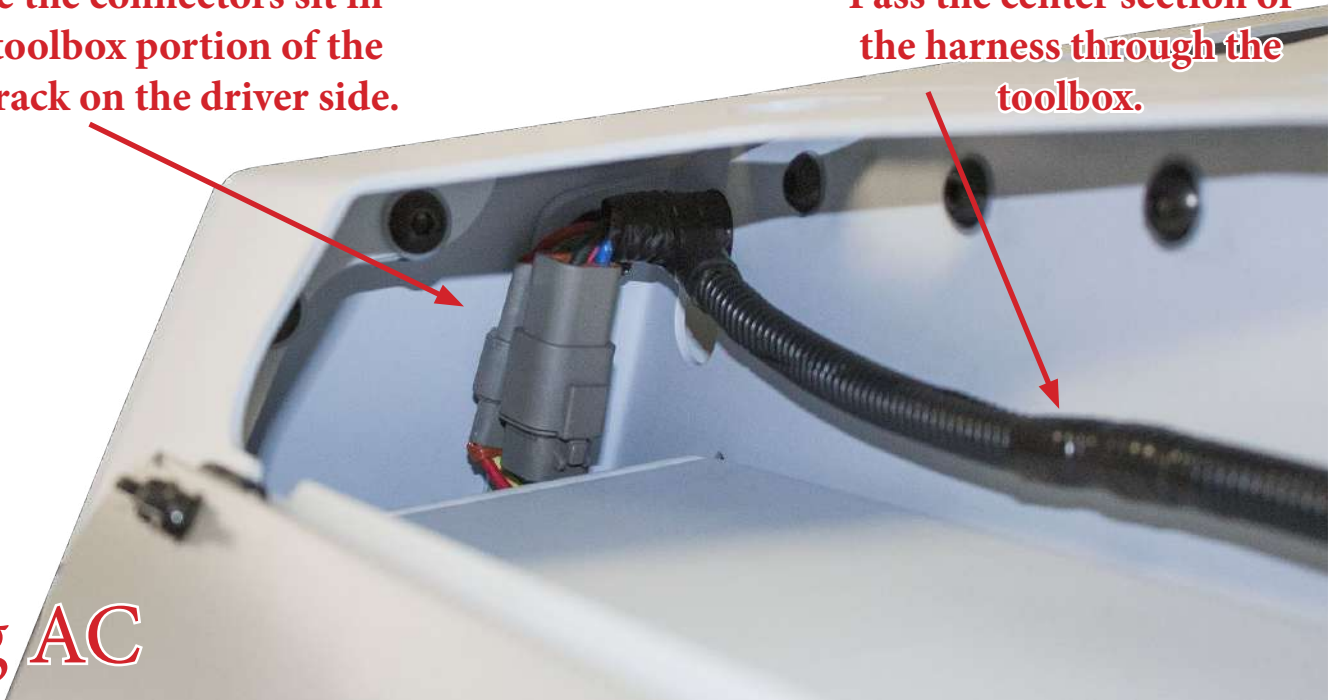

Fig AC

27. There are six connectors on the upper harness. Each of those connectors has a green wire running next to it. Cut the connectors off and cap the green wire. (Fig AD)

Before

After

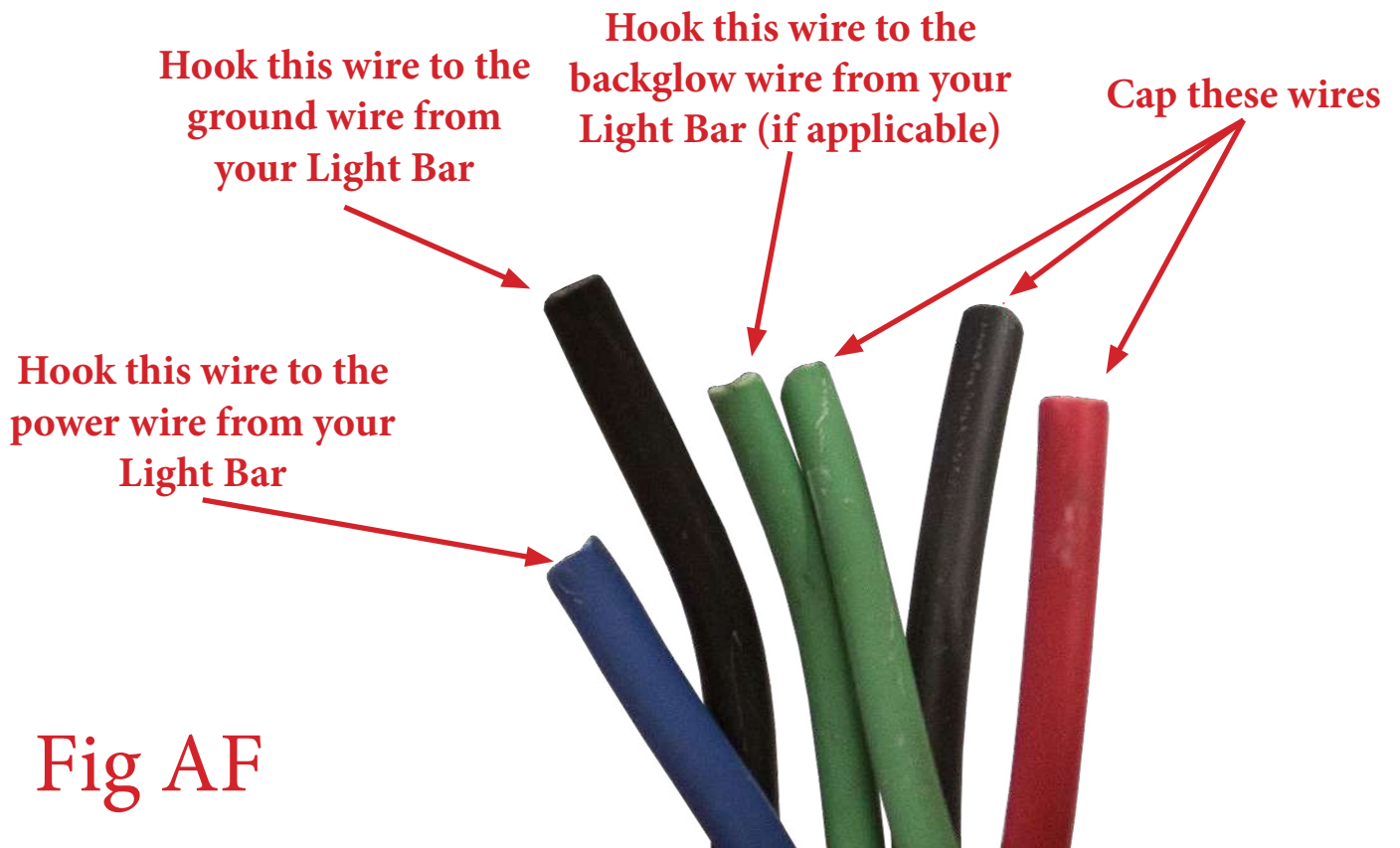

Fig AD

28. Using butt connectors, connect the remaining red and black wires from Step 27 to the red and black wires from your Rigid Ignite lights. Then, conceal the wires and zip tie them up and out of the way. (Fig AE)



29. Find the group of blunt cut wires on the roof rack harness, right by your 40" Light Bar. Hook the blue wire from the harness to the power (red on Rigid Lights) wire from your 40" Light Bar. If your light has backglow, hook the backglow wire from your light bar (white wire on Rigid Lights) to one of the green wires from the roof rack harness. Finally, hook the ground wire from your light bar (black wire on Rigid Lights) to one of the black wires in the roof rack harness. Cap the rest of the unused wires. (Fig AF)



30. Plug the bottom portion of the chase rack harness into the upper portion. Then, send the long leg of the harness between the truck cab and bed on the driver side of the vehicle. (Fig AG)



31. There is a section of the lower harness that branches off right where the roof rack and main rack meet. Send that section of wiring to the SRQ that is mounted in the third brake light position of the main rack. Hook the Orange wire from the harness to the Red wire from the SRQ. Hook the Brown wire from the harness to the White wire from the SRQ. Hook the Black wire from the harness to the Black wire from the SRQ. (Fig AH)

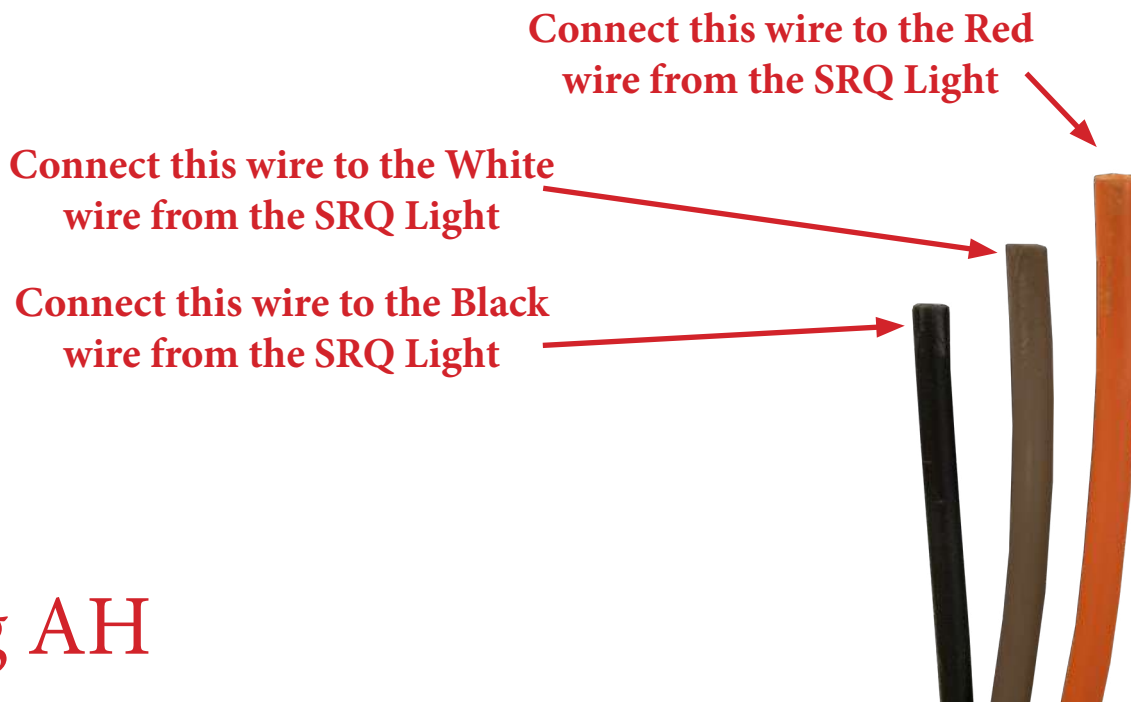

33. Run the main harness leg from Step 30 underneath the vehicle, zip-tying it up and out of harm's way as you go. There is a branch off with a single orange wire in it. That will need to be passed into the cab of the truck. The following steps will show you how to do that.

34. Open the driver side door and remove the two kick panels. There are no tools required for this step, they simply pull off by hand. (Fig AI)

Before

After



Fig AI

32. From underneath the truck, find the body plug referenced in (Fig AJ). Then, drill a hole through that plug large enough to pass the orange wire from the harness through. Pass that wire through this hole and into the body of the vehicle.



Fig AJ

35. Behind the kick panels you removed in Step 34, there is group of blunt cut wires. Within this group of wires, there is a purple wire with a grey stripe. Connect the orange wire from the chase rack harness to this purple wire with a grey stripe. (Fig AK)

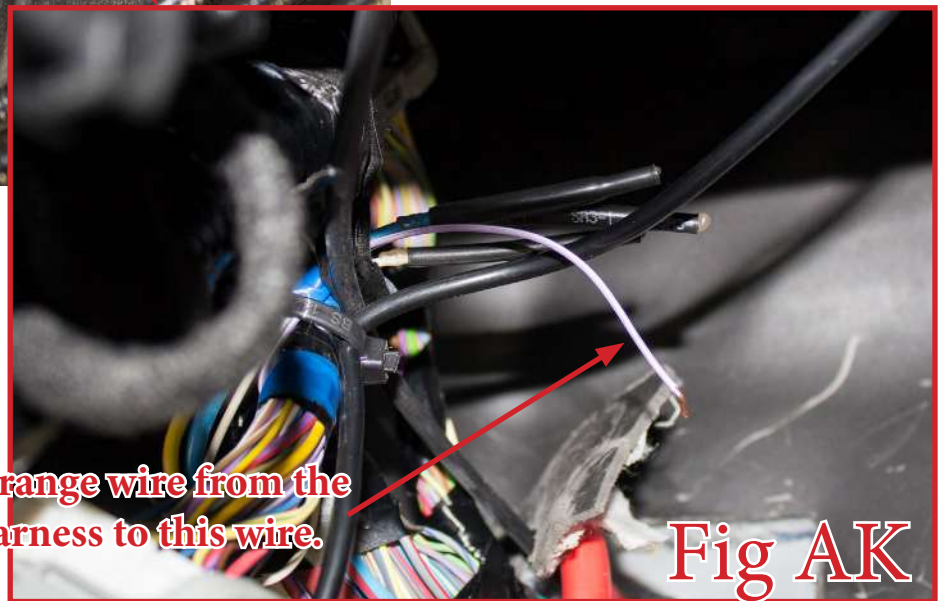

Connect the orange wire from the chase rack harness to this wire.

Fig AK

36. Put the two kick panels from Step 34 back into place.

37. Underneath the truck, there is a black wire with an eyelet attached to the end of it. Connect that eyelet to a suitable ground. You can use a self tapping screw into the vehicle's body mount or frame rail. You can also use any OEM ground location that is nearby. (Fig AL)



Fig AL

- 38. Run the remainder of the chase rack harness up into the engine bay on the driver side. Zip tie it up and out of harm's way as you go.
- 39. There is a branch off the harness with a single brown wire in it. That will get connected to the running light wire from your headlight connector. To do this, first disconnect the connector from the back side of your driver side head light. (Fig AM)



Fig AM

- 40. Using the supplied blue splice connector, connect the brown wire from the chase rack harness to the green/orange wire from the headlight connector. (Fig AN) explains how the connector works, while (Fig AO) shows how it will look once the connection is made. After you make this connection, plug the headlight connector back in.

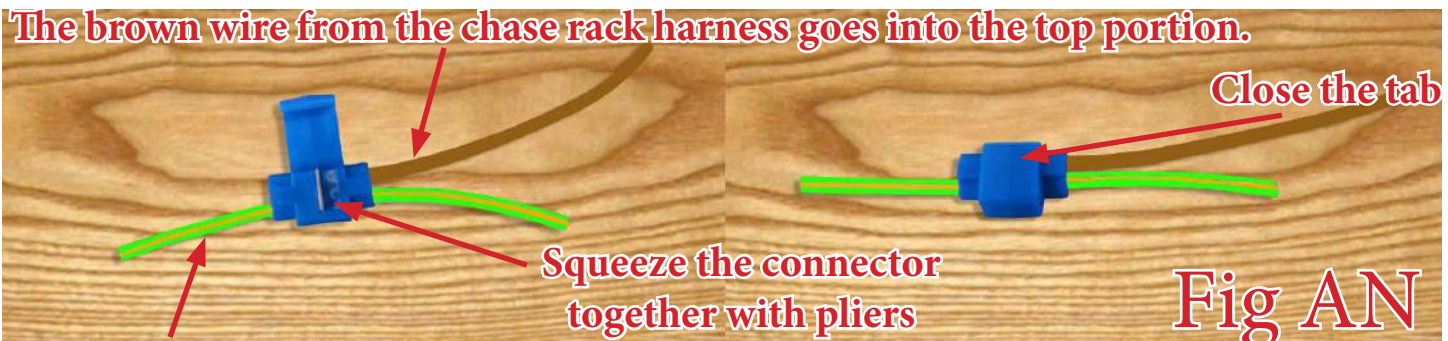

The brown wire from the chase rack harness goes into the top portion.

Close the tab

Squeeze the connector together with pliers

Fig AN

The green/orange wire from the headlight connector goes into the bottom portion



Fig AO

41. Find the bundle of wires remaining in the chase rack wiring harness. There should be one pink, one red, one yellow, one blue, and one green wire left. You will have to run the light manufacturer's wiring harness in conjunction with our wiring harness for your 40" Light and Ignite Lights. **If you are using a 40" Light Bar with backglow, follow this step. If your 40" Light Bar does not have backglow, follow the next step instead.** Run the manufacturer's harness how they tell you to run it, except the red/black/white wires going to the light bar. Connect that Red wire from the light bar harness to the Blue wire from the chase rack harness. Connect the White wire from the light bar harness to the Green wire from the chase rack harness. Cap the black wire on the light bar harness. (Fig AP)

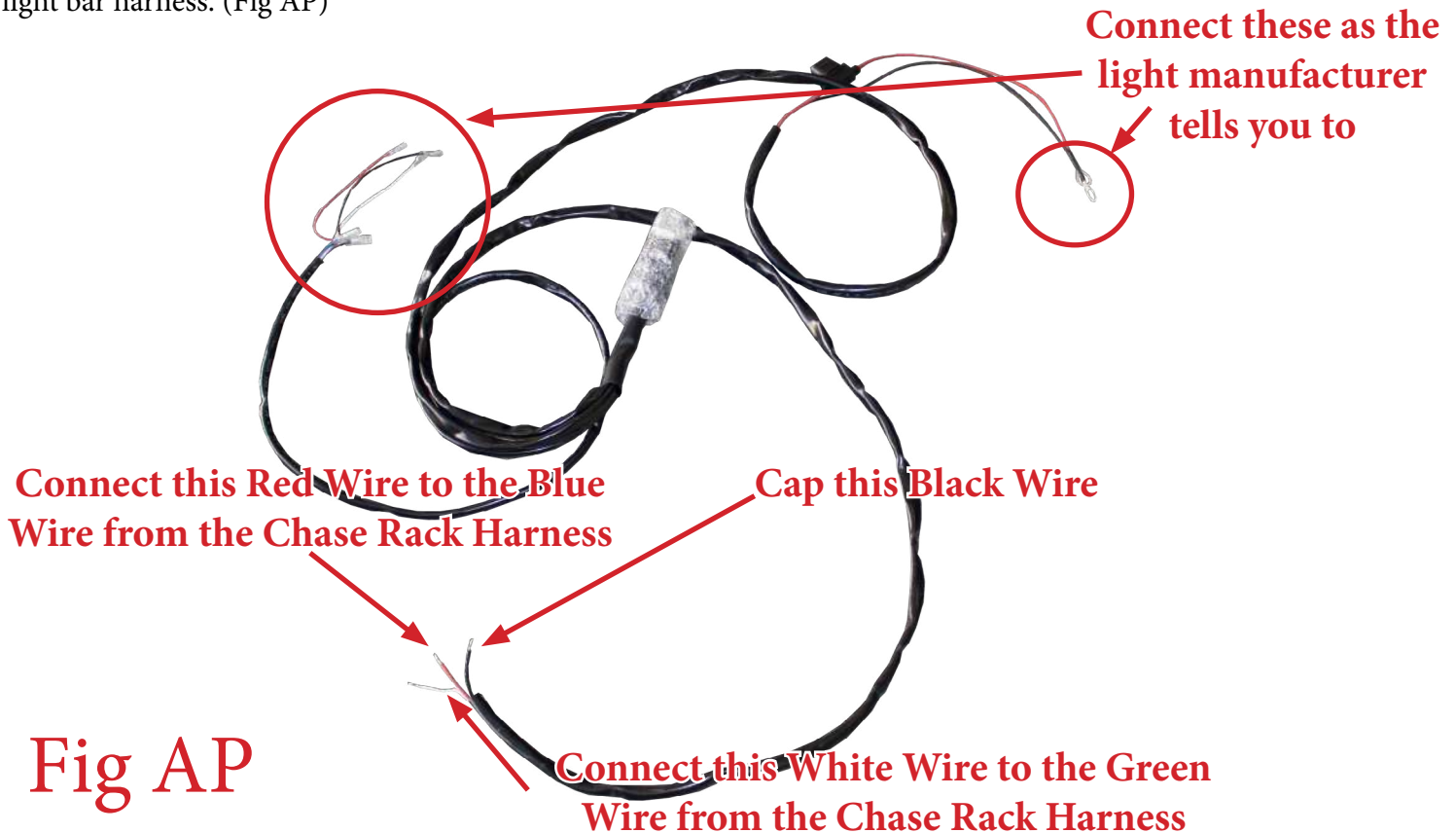
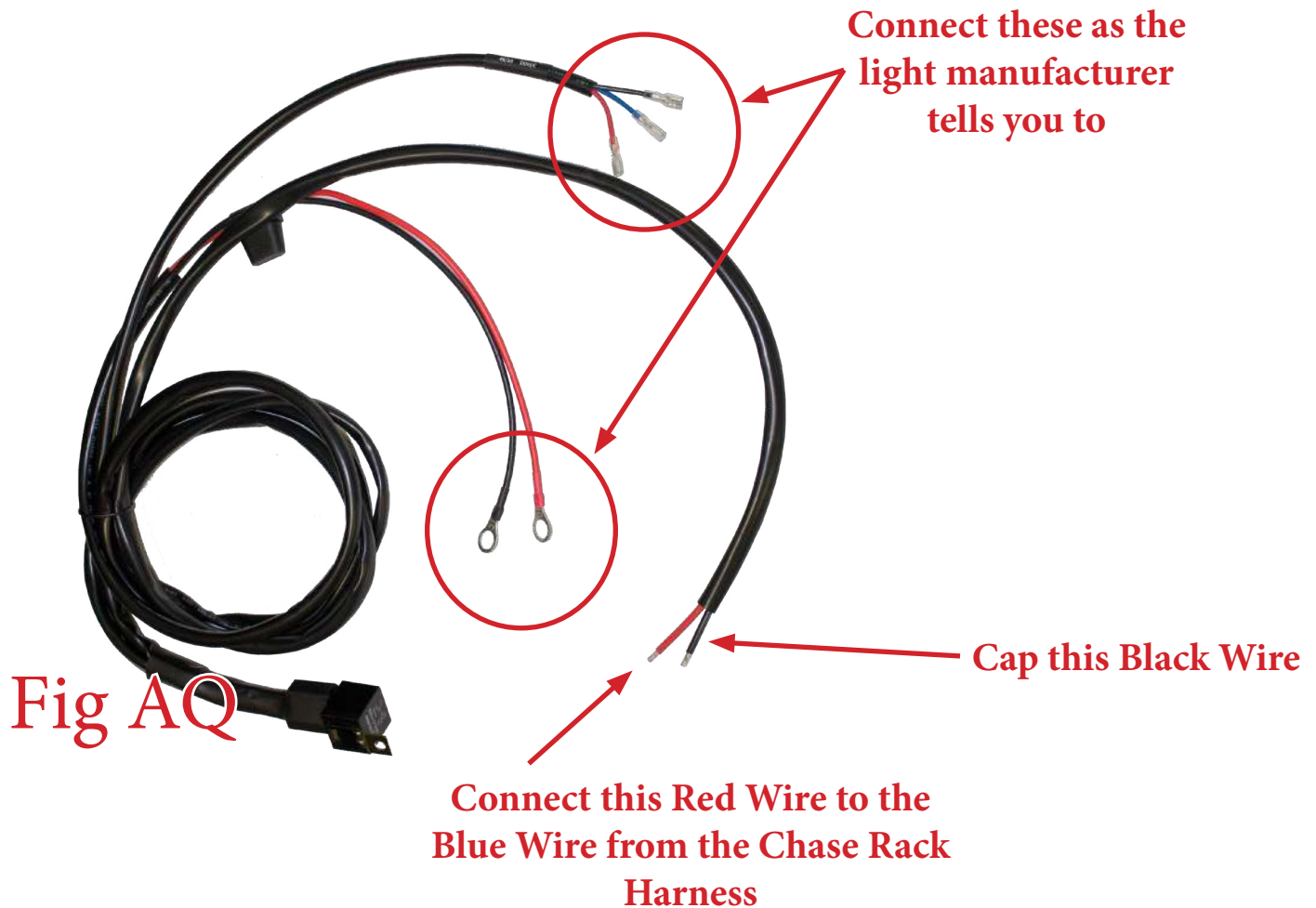
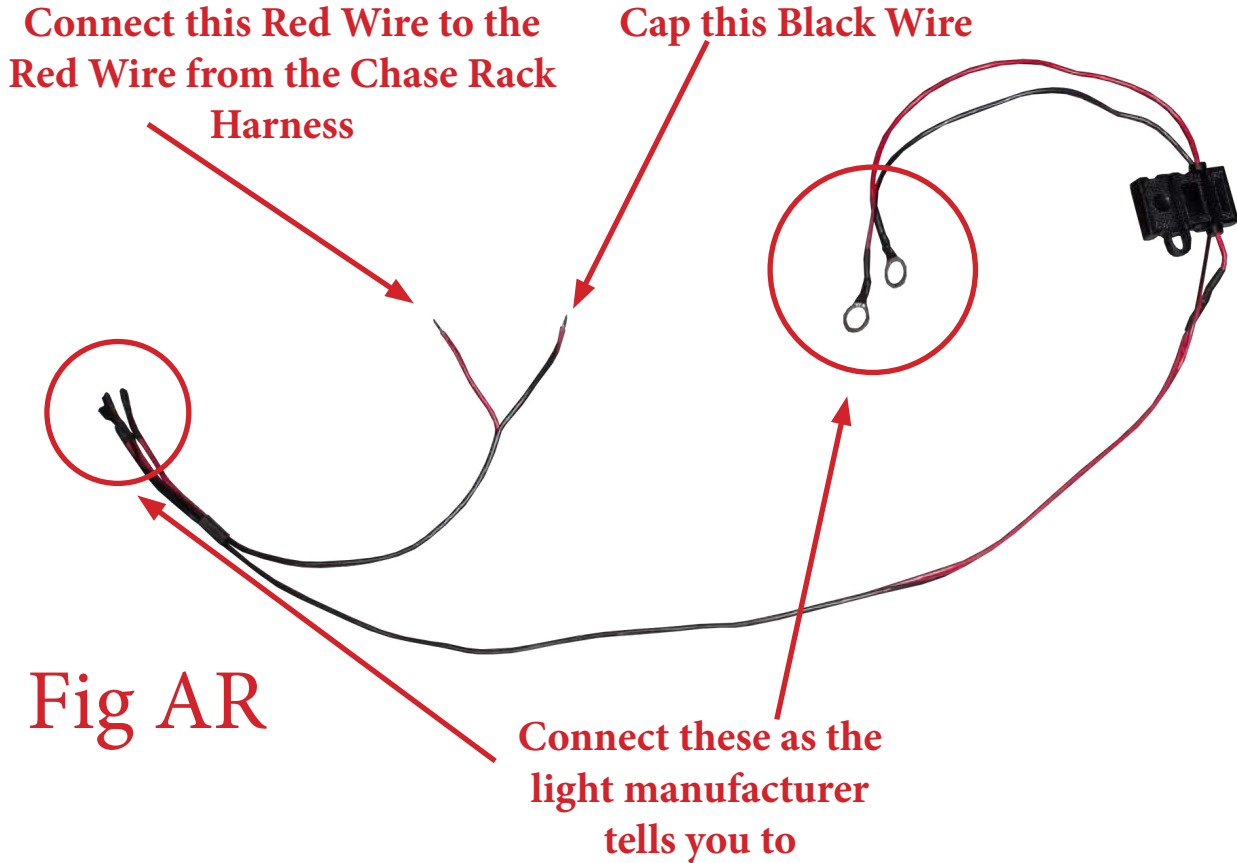

Fig AP

42. Find the bundle of wires remaining in the chase rack wiring harness. There should be one pink, one red, one yellow, one blue, and one green wire left. You will have to run the light manufacturer's wiring harness in conjunction with our wiring harness for your 40" Light and Ignite Lights. **If you are using a 40" Light Bar without backglow, follow this step. If you are using a 40" Light Bar with backglow, follow the previous step.** Run the manufacturer's harness how they tell you to run it, except the red/black wires going to the light bar. Connect that Red wire from the light bar harness to the Blue wire from the chase rack harness. Cap the black wire on the light bar harness. You can also cap the Green wire on the chase rack harness. (Fig AQ)



43. Find the harness that came with your Rigid Ignite lights. Run that harness as the light manufacturer tells you to except, the red/black wires that go to the ignite lights. Connect that red wire from the Ignite harness to the red wire from the chase rack harness. Then, cap the black wire on the Ignite harness. (Fig AR)



44. Cap the remaining wires in the Chase Rack Harness (one pink and one yellow).
45. Stand back and enjoy your new ADD HoneyBadger™ Chase Rack.
46. Check and re-tighten, if needed, all mounting bolts after 100 miles and periodically thereafter.

