

# Rules for Safe Automotive Testing

READ CAREFULLY

*Read this Operation Instruction Manual and these Rules for Safe Automotive Testing carefully.*

1. Before starting the engine, set the parking brake and place the gear selector in NEUTRAL on standard transmissions and PARK on automatic transmissions.
2. The carbon monoxide in exhaust gas is highly toxic. To avoid asphyxiation, always operate vehicle in a well-ventilated area. If vehicle is in an en-

closed area, exhaust should be routed directly to the outside via leak-proof exhaust hose.

3. An automobile battery is capable of producing very high currents. Therefore, exercise reasonable care when working near the battery to avoid electrical connections through tools, wristwatch, etc.
4. Always wear safety glass eye protection.
5. Keep hands, hair, necktie, loose clothing and test leads well away from fan blades, fan belt, power steering belt, air conditioner belt and other moving engine parts as serious injury could result from entanglement.

6. Do not touch hot exhaust manifold, radiator or high-voltage spark plug and coil terminals. Spark voltages are not normally lethal, but an involuntary jerk of the hands or arms caused by electrical shock may result in injury.
7. Never look directly into carburetor throat while engine is cranking or running. A sudden backfire can cause serious burns.
8. To avoid the possibility of a flash fire, do not smoke or permit flame or spark to occur near carburetor fuel line, fuel filter, fuel pump or other potential sources of spilled gasoline or gasoline vapors.

---

## Introduction

Vacuum is developed by all internal combustion engines during the intake stroke of the combustion process. As the piston travels downward to the bottom of its stroke it creates an "empty space" or vacuum. It is this downward stroke which draws the air/fuel mixture into the cylinder. Because the ratio of air to fuel is critical, it is important that the entire induction system (intake manifold, carburetor or throttle body, and all vacuum-driven devices and hoses) be tight, properly connected and free of leaks. Your Vacuum Pump will give you the capability to check vacuum levels within the system as well as apply vacuum to any of the many vacuum operated devices found on the modern vehicle. This manual will outline some of the more common uses of your vacuum pump, however it cannot take the place of your vehicle service manual, where you will find complete diagnostic and test procedures which require the use of the vacuum pump.

---

## Typical Applications

The following list shows some of the more common applications and tests that your vacuum pump can do.

1. **Carburetor Service**
  - Choke pull-off diaphragm
  - Vacuum break diaphragm
2. **Ignition System Service**
  - Vacuum advance unit
  - Vacuum retard unit
3. **Computerized Engine Control Systems**
  - Vacuum transducer MAP sensor
4. **Emission Control Systems**
  - Thermal vacuum switches
  - Vacuum delay valves
  - Heated air intake systems
  - EGR (Exhaust Gas Recirculation) valves
5. **Automatic Transmission Modulator Valves**

## CAUTIONS AND NOTES ON THE USE OF THE VACUUM PUMP

- The gauge on the unit is a carefully calibrated device which will not withstand physical abuse. Handle the unit with the same care you would give any precision tool.
- Do *not* use the vacuum pump to siphon liquids as internal seal damage may result.
- Some vacuum units have calibrated leaks built into them. These are in the form of a very tiny hole in the metal housing on the unit. In order to test the diaphragm for leaks on this type of unit it is necessary to plug this hole with tape or other suitable means. Make sure to remove the tape when testing is complete.

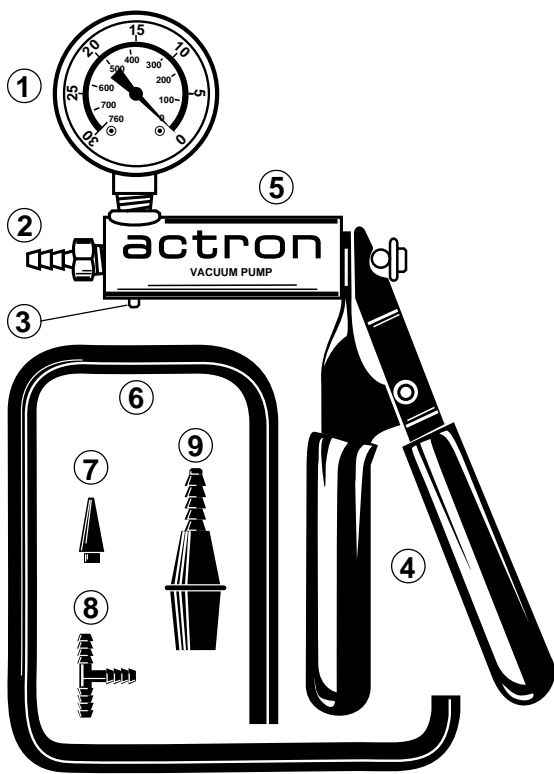

## Description

The vacuum pump's parts and their respective functions are as follows:

- ① **Vacuum Gauge** – This two (2) inch gauge reads the vacuum in the system under test. It is calibrated in both inches of mercury (0-30) and millimeters of mercury (0-760) making it compatible with both domestic and metric specifications.
- ② **Vacuum Fitting** – Attach the supplied 24-inch rubber hose to this fitting.
- ③ **Vacuum Release Valve** – Depress this valve to release vacuum.
- ④ **Handles** – Grip the pump by the handles and squeeze them together to "draw" a vacuum.
- ⑤ **Pump Body** – This is the pump which includes the cylinder, piston and valve mechanisms used to pump the vacuum.

### Accessories

The following accessories are supplied with the unit and are used as follows:

- ⑥ **Vacuum Hose (24")** – Securely attach one end of the hose to the vacuum fitting on the pump, and the other end to an adapter (described below).
- ⑦ **Tapered Hose Adapter** – Allows connection of the vacuum pump to varying inside diameters of "on car" vacuum hoses. Connect the non-tapered side to the 24" vacuum hose which connects to the pump.
- ⑧ **"Tee" Fitting** – Use this fitting when it is necessary to insert the vacuum pump inside a "complete vacuum circuit". This provides an easy method to use the vacuum gauge portion of the unit for monitoring vacuum of a particular system with the engine running.
- ⑨ **Universal Adapter** – Use this adapter to fit metal tubing, flared fittings and large hoses such as the PCV or power brake booster lines.

## Replacement Parts

Key No. (See illustration)	Part No.	Description
1	CP7830-101	Vacuum Gauge*
2	CP7830-102	Barbed Vacuum Fitting*
3		Vacuum Release Valve (See repair kit below)
6	CP7830-103	24" Rubber Vacuum Hose
7	CP7830-104	Tapered Hose Adapter
8	CP7830-105	"Tee" Fitting
9	CP7830-106	Universal Adapter
Not shown	CP7830-107	Vacuum Pump Repair Kit** Consists of 1 each: U-form Piston Ring O-ring Bleed Valve (Black) Umbrella Valve Vacuum Release Valve (white or clear)

\* When replacing the Vacuum Gauge or Barbed Vacuum Fitting, it is important to maintain a good seal. Wrap a layer of teflon tape around the gauge or fitting before threading it into place on the pump body.

\*\* All of the parts in this kit except the Vacuum Release Valve are installed inside of the brass pump body. The pump body consists of three (3) parts screwed together. To install the kit parts, simply unscrew the three (3) pump body parts from each other. Remove the old parts and install the new parts carefully. It is important that the brass surface under the umbrella valve be smooth, clean and dry. Be careful not to interchange the **BLACK** bleed valve with the **WHITE** or **CLEAR** vacuum release valve.

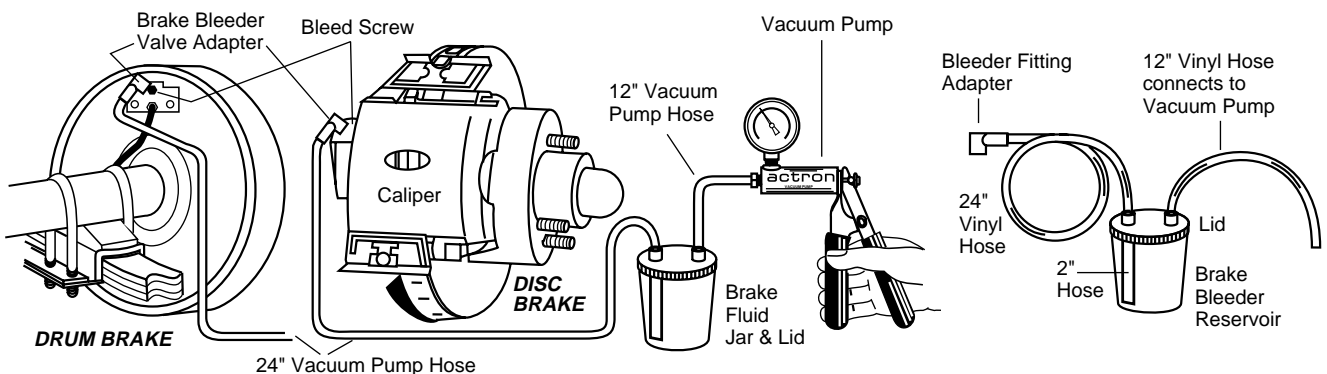

[View other brake service tools made by Actron on our website.](#)