

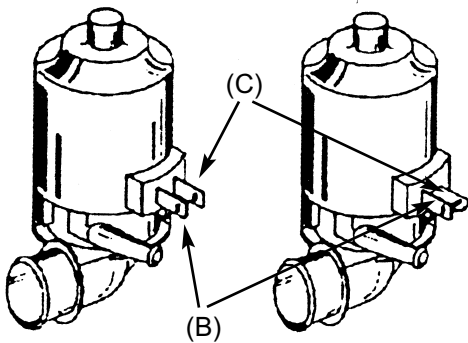

Instructions

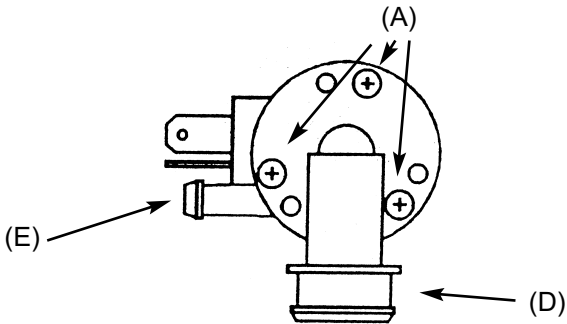

- (A) Nozzle Plate Mounting Screws
(B) Positive Terminal (+)
(C) Negative Terminal (-)
(D) Inlet Nozzle
(E) Outlet Nozzle.

Instructions

Do not use pump without solvent.

Note: This replacement pump may not resemble the pump you are replacing. However, it will fit in form and function

- 1) Disconnect electrical and hose connections.
- 2) Remove tank with pump installed then remove pump.
- 3) If electrical connections are different - see splicing instructions on other side.
- 4) If inlet & outlet nozzles have a different orientation - follow step no. 5.
- 5) Remove nozzle plate mounting screws and rotate plate until nozzle orientation is similar to old pump. Install screws.
- 6) Clean and flush tank.
- 7) Install new pump and seal. Refit tank.
- 8) Attach electrical and hose connections.
- 9) Refill tank with proper solvent.
- 10) Prime the pump by activating 4 to 6 times.

Splicing Instructions

Do not cut existing wiring!

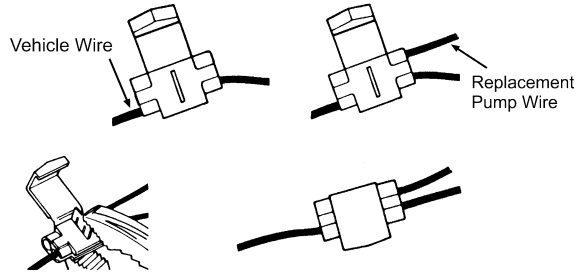

- 1) Identify vehicle positive (+) and negative wires (-). Usually red is (+) and black is (-).
- 2) Positive terminal on replacement pump is indicated on other side.
- 3) Insert positive or negative wire on vehicle into one splicer channel.
- 4) Insert wire from replacement pump wire harness into the other splicer channel. Red is (+) and black is (-).
- 5) Use pliers to press splicer tab onto wires.
- 6) Fold cover over and clip in place.
- 7) Repeat with remaining wire.