



By ACCEL Motorcycle Products



INSTALLATION INSTRUCTIONS

IGNITION MODULE PN A605 FOR HARLEY DAVIDSON

INSTALLATION AND ELECTRICAL WIRING PROCEDURE

- Step 1:** Apply a thin coat of silicone grease to the bottom of the module before mounting the module to its plate in the distributor.
- Step 2:** Slide the three wires from the MODULE, through the grommet, to outside the distributor housing. Put the three wires from the MODULE in the TERMINAL PIN HOUSING: GREEN WIRE in hole #1, BROWN WIRE in hole #2, RED WIRE in hole #3. Plug the three wire harness (PN 29349, not supplied with this kit) into the TERMINAL PIN HOUSING.

RED WIRE: Power/voltage for the MODULE. Connect to coil (+) terminal.

GREEN WIRE: Ignition trigger. Connect to coil (-) terminal.

BROWN WIRE: Ground for the MODULE. Connect to ENGINE BLOCK GROUND. Clean away any grease, oil, and paint from the mounting surface before the connection is made.

SINGLE PLUG HEADS

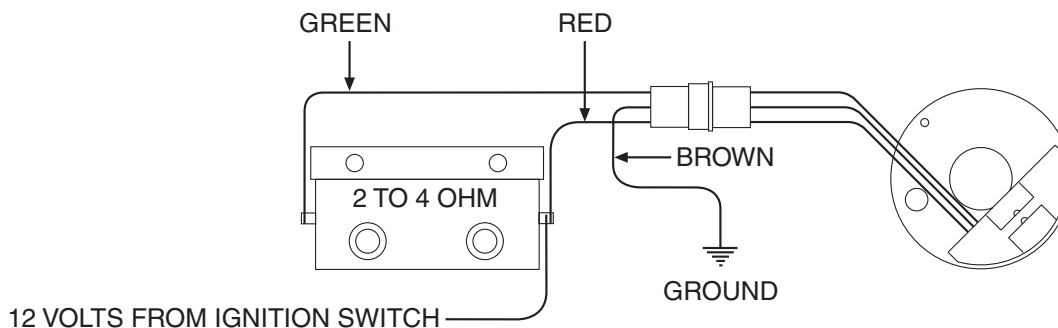

DUAL PLUG HEADS

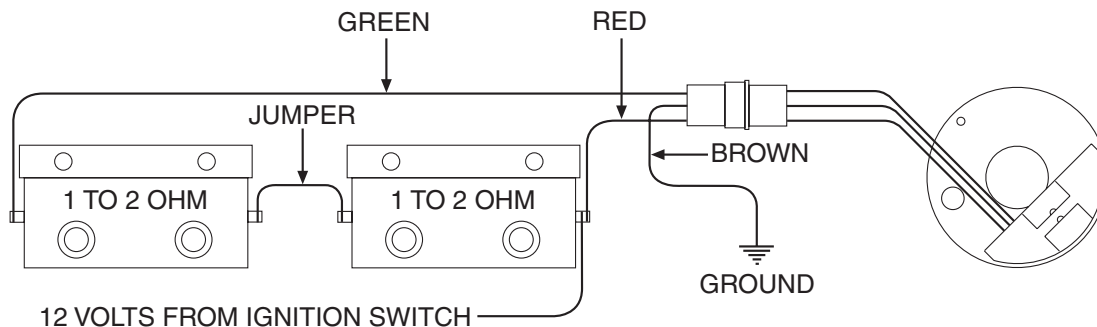

Learn more about performance ignition systems we have.