

Tilt Steering Column Instruction Sheet

PLEASE READ BEFORE YOU BEGIN TO INSTALL COLUMN

Flaming River all new parts pledge.

The best in the business and a three-year warranty. Flaming River tilt steering columns come complete with aluminum dress-up kit, which includes: turn signal arm with Phillips screw, tilt lever, hazard knob with screw, and steering wheel hold nut. Flaming River also has a full range of steering column accessories including steering wheels, custom wheel adapters, floor mounts, and column drops.



INDEX

Page	Description
1	Non-Key Tilt Steering Column Installation
2	Key Tilt Steering Column Installation
3	Key Tilt Steering Column Ignition Wiring
4	Neutral Safety Switch (Column Shift Only)
5	FR20300 Stramp Clamp Installation
6	Gear Shift Arm Installation (Column Shift Only)
7	Turn Signal Wiring

STEERING COLUMN INSTALLATION TIPS

- Be sure the column you have selected is the proper length before you begin installation.
- DO NOT activate the column “tilt” mechanism before installation. This can cause injury or damage to the column.
- You must install a neutral safety switch on all automatic transmissions. Your vehicle will start in any gear without it.
- The end of the Flaming River column is a 1”DD hollow shaft and Flaming River has a complete line of universal joints and shafts available to complete your steering installation after the column is installed in your vehicle.



PARTS LIST

Qty	Description
1	Steering Column
1	Wire Harness, with GM 4-1/4” male connector
1	Canceling cam, compression spring and Horn contact wire
1	Steering wheel hold down nut
1	Dress-up kit

TILT STEERING COLUMN INSTALLATION

1. Determine the floor mount you intend to use and dash board clamp or column drop.
2. Position the floor mount at the bottom of the steering column. Do not fully tighten the mount until the column is in its final position.
3. Install the column in the vehicle and install the dash clamp or column drop to hold the column in place. Next, re-adjust floor mount to fit snug to the floor and make any final adjustments before tightening all the clamps.
4. Install the turn signal arm using the phillips screw provided. Then the tilt arm, and finally the hazard knob using the allen screw provided.
5. Connect the GM 4-1/4" male plug to your vehicle wiring harness. (You May need a wiring adapter, part # FR20118-4)

INSTALLING THE STEERING WHEEL

The spline on your new Flaming River steering column is a GM spline designed from 69 to present steering wheels without an airbag. The horn wire is furnished with your steering column and is pre-installed into the canceling cam.

INSTALLING THE CANCELING CAM (NON-KEY COLUMN)

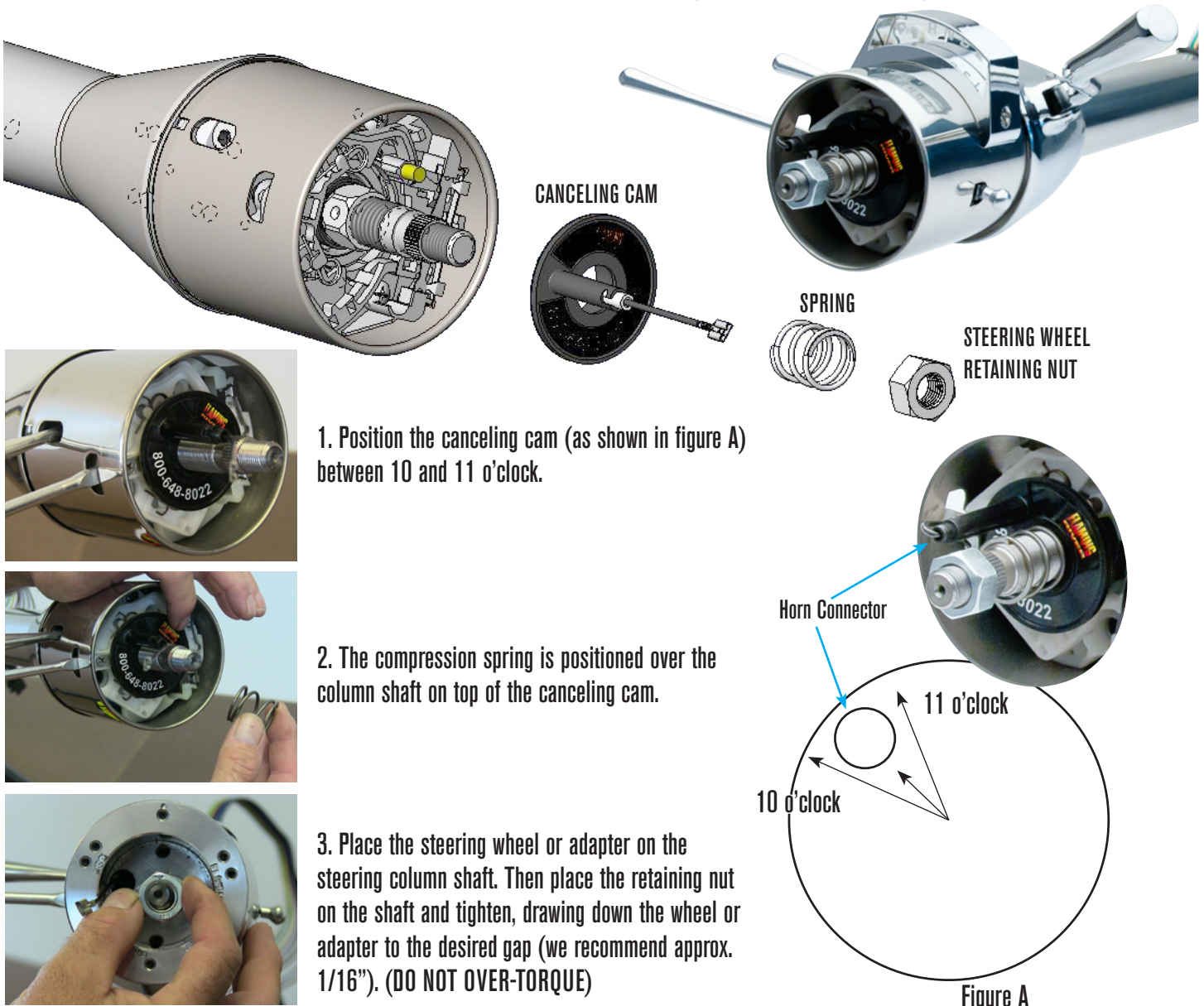

INSTALLING THE CANCELING CAM (KEY COLUMN)

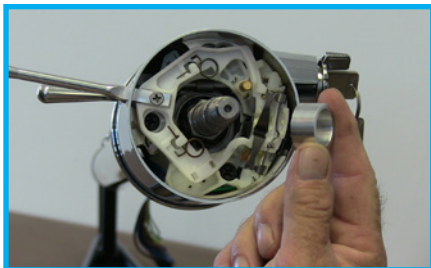
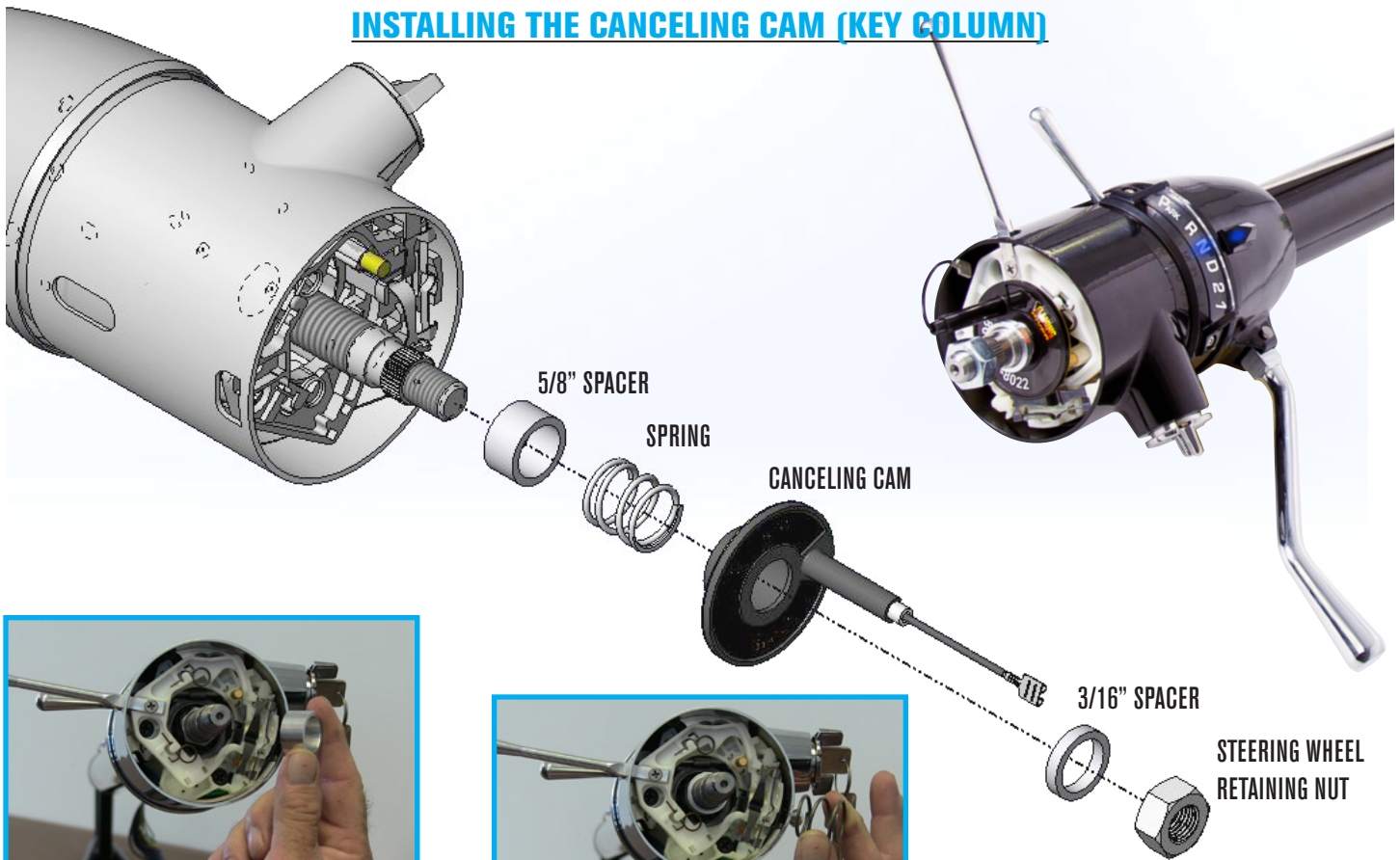

1. Install the large 5/8" aluminum spacer over the column shaft.

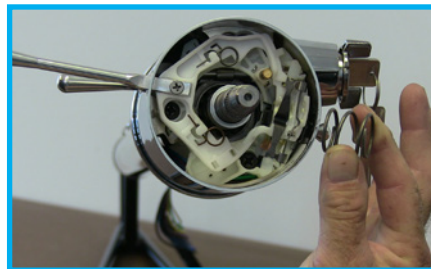

2. Next install the Canceling Cam Spring over the column shaft and down to the 5/8" aluminum spacer.

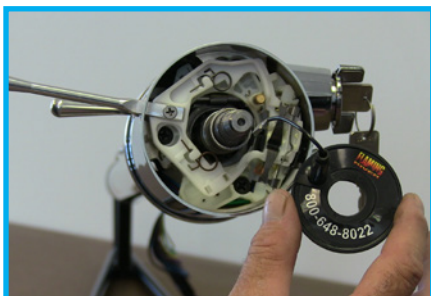

3. Then, slide the Canceling Cam over the column shaft and canceling cam spring. *For proper operation of the canceling cam, align the canceling cam stem between the 10 and 11 o'clock position. (figure A)*

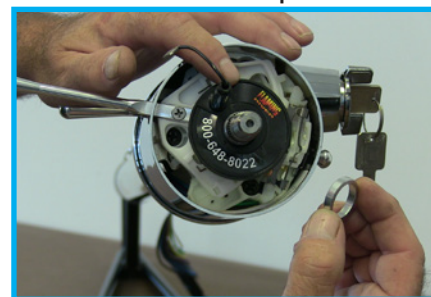

4. Place the final 3/16" aluminum spacer over the column shaft and down to the canceling cam.

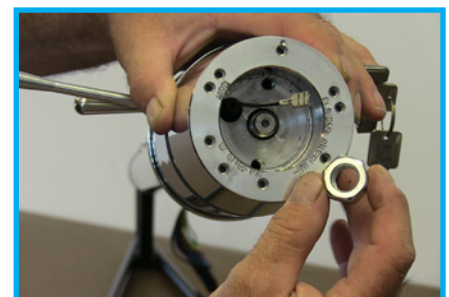

5. When installing your steering wheel adapter, tighten the retaining nut to 50 ft. lbs.

IMPORTANT: (FOR KEY AND NON-KEY COLUMNS)

A spring-loaded horn contact connects to the underside of the canceling cam.

When connecting the canceling cam to your horn button, please note: The BLACK WIRE is only designed for momentary ground to trigger a horn relay. DO NOT connect voltage to the BLACK WIRE, or permanent damage to the column wiring or other components will occur.



KEY TILT STEERING COLUMN IGNITION WIRING

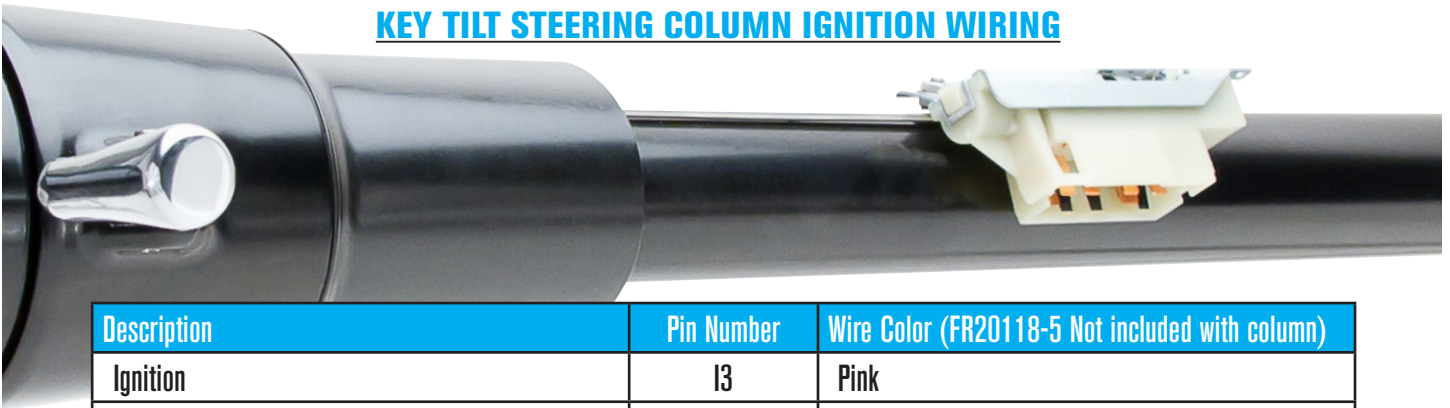

Description	Pin Number	Wire Color (FR20118-5 Not included with column)
Ignition	I3	Pink
Solenoid	S	Purple
Ground	G1	
Battery	B3	Red
Battery	B2	Red
Battery	B1	Red
Ground	G2	
ACC	A	Brown
Ignition	I1	Pink - Hot when wired

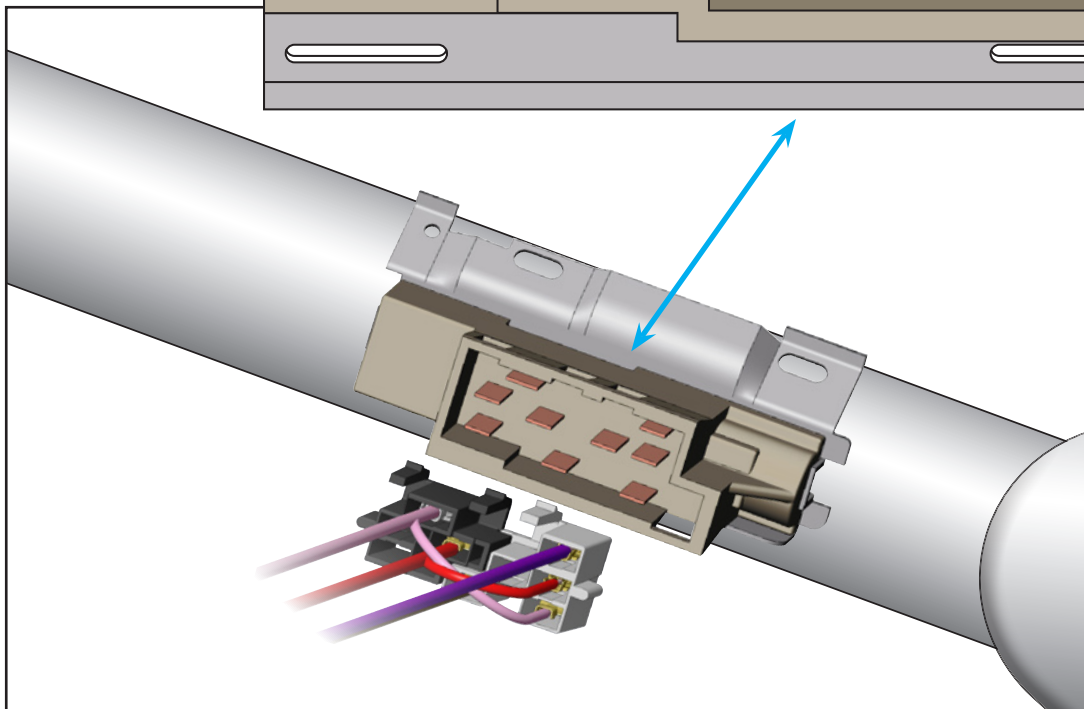
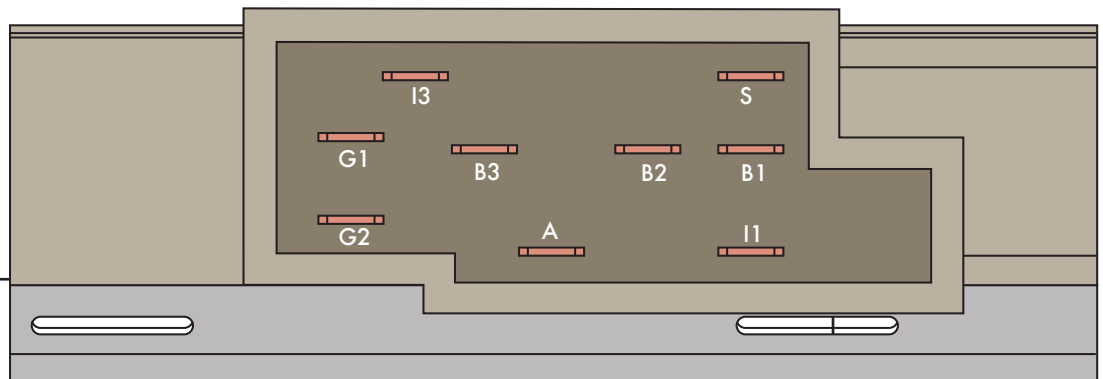

IGNITION SWITCH DETAIL

Figure A

NEUTRAL SAFETY SWITCH

Note: For this switch to work correctly, you must have your gear shift linkage adjusted properly with the detents in the transmission.

Adjustment:

1. Remove neutral safety switch from column by removing the two retaining screws.
2. While holding the back of the neutral safety switch towards you, align the slotted tab with the first hole from the left. This is the neutral position in the switch. Place a pin (straightened paper clip) in the hole to retain this position. (see figure A)
3. Place the gear shift indicator in the neutral position.
4. Place the neutral safety switch onto the column and snug down the switch with the screws that were removed in step one.
5. Reattach your wiring, ensuring that the neutral safety wires are on the two flat terminals and the reverse lights are on the two offset terminals. (see figure B)
6. Move the gear shifter through the range of gears, it should only start in neutral and park.

Fig A

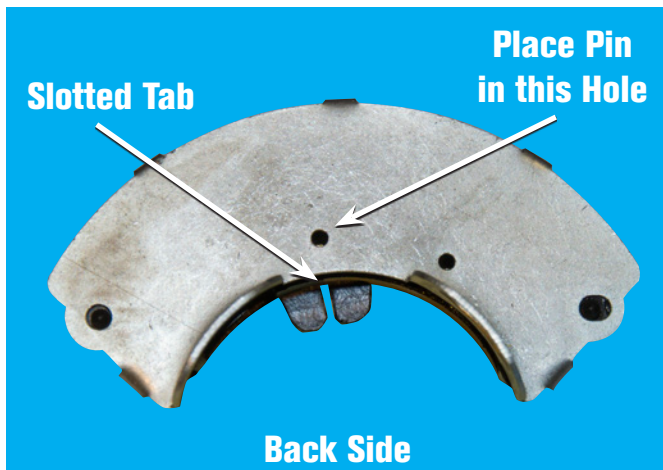
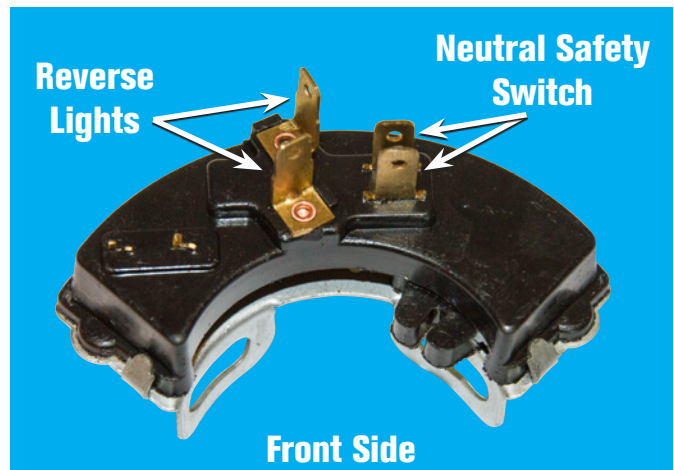

Fig B



Important Safety Note:
You must install a neutral safety switch on all automatic transmissions. Without a Neutral Safety Switch your vehicle will start in gear.



FR20300 STRAMP CLAMP

This clamp has been developed to allow the end user to use the original GM mounting bracket under the dash that positions the steering column. The Stramp Clamp allows for full adjustability of the steering column for maximum driving comfort.

- Step 1: Remove the original steering column and mounting bracket from the car.
- Step 2: Take a few measurements to determine where you would like the new steering column to be located. With help from someone, position the new column through the firewall and into the final position.
- Step 3: Place the original mounting bracket from the vehicle around the column so that the mounting holes line up with the frame and determine where the column clamp needs to be placed on the column. Once this is determined, place the set screws in the sides of the column clamp as shown below. Tighten until the screws are snug, but not cutting through the rubber membrane or you will run the risk of scratching or marring the column tube.
- Step 4: Mount the column clamp to the original mounting bracket using the original hardware (5/16-18 bolts) and then mount the bracket to the frame under the dash.

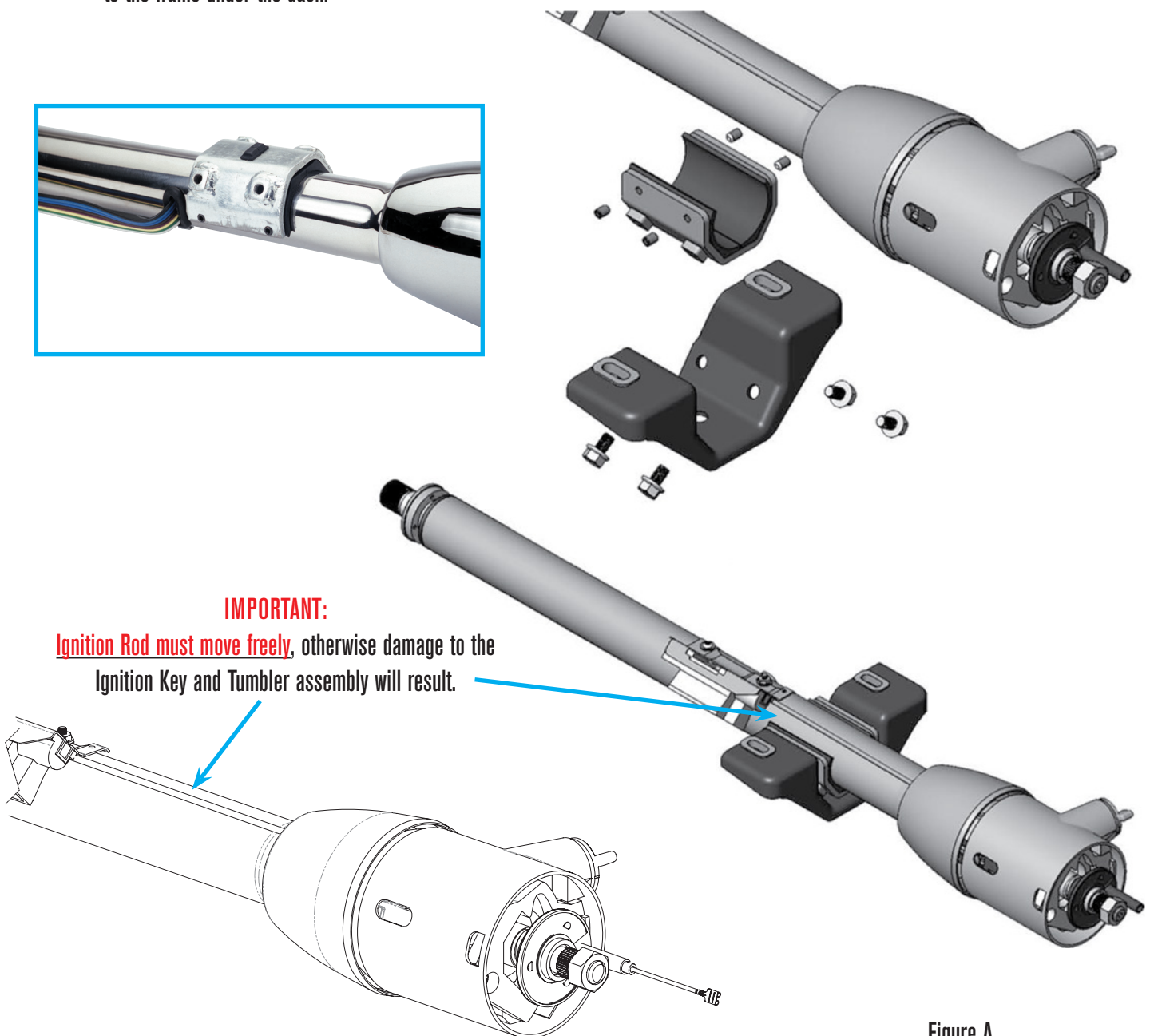
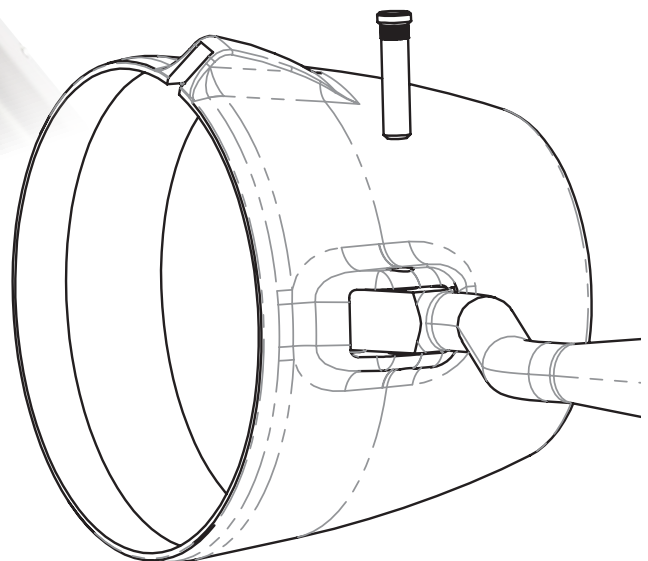
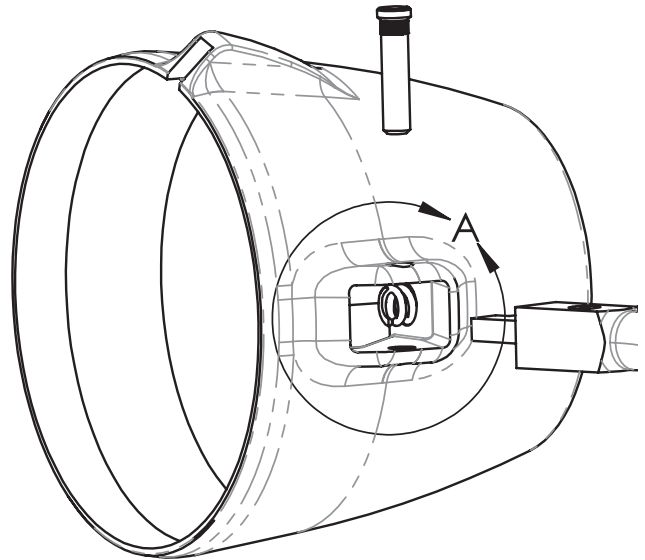
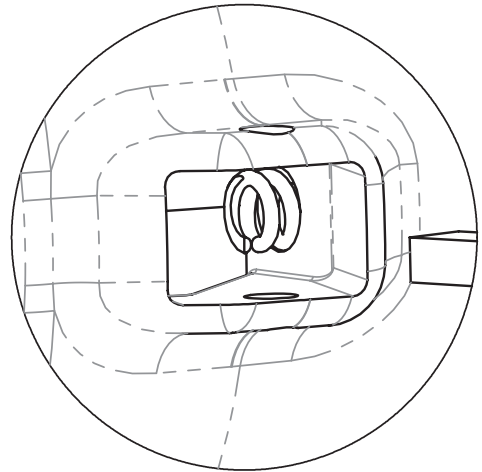

Figure A

GEAR SHIFT ARM INSTALLATION - APPLIES TO COLUMN SHIFT COLUMNS ONLY

1. Grease spring and insert it into the casting hole. Care must be taken not to drop the spring into the casting. Grease and a small screw driver may help with installation.
2. Position the arm into the casting so the pin hole in the arm is in relation to the pin hole in the casting.
3. Grease the smooth end of the pin and start it into the casting pin hole.
4. Using a hammer and drift, gently tap the pin into the casting until flush. **DO NOT USE EXCESSIVE FORCE** - this may damage the casting.



THE WIRING INCLUDED WITH YOUR FLAMING RIVER COLUMN IS A GM 4-1/4" CONNECTOR.

THE STANDARD GM WIRING IS LISTED BELOW.

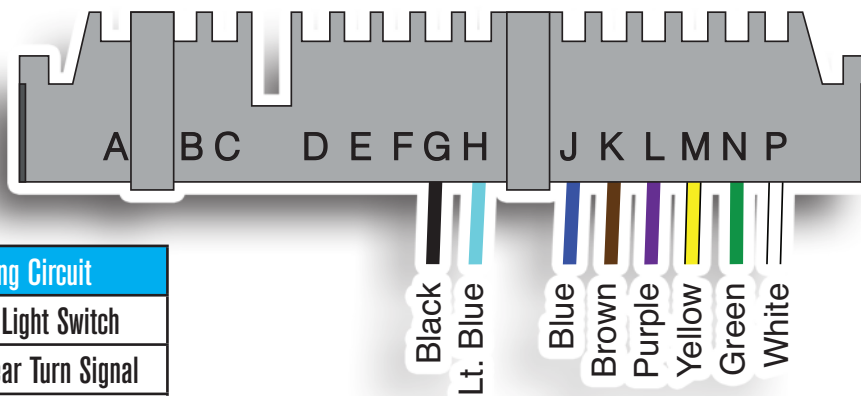

Pin Location	Column Wiring	Wiring Circuit
P	White	Brake Light Switch
N	Dark Green	Right Rear Turn Signal
M	Yellow	Left Rear Turn Signal
L	Purple	Turn Signal Power
K	Brown	Hazard Power
J	Dark Blue	Right Front Turn Signal
H	Light Blue	Left Front Turn Signal
G	G	Horn

NOTE: If your vehicle (female plug) is not the correct size, you can purchase one of the adapter kits below.



FR20118
Female Wiring Adapter

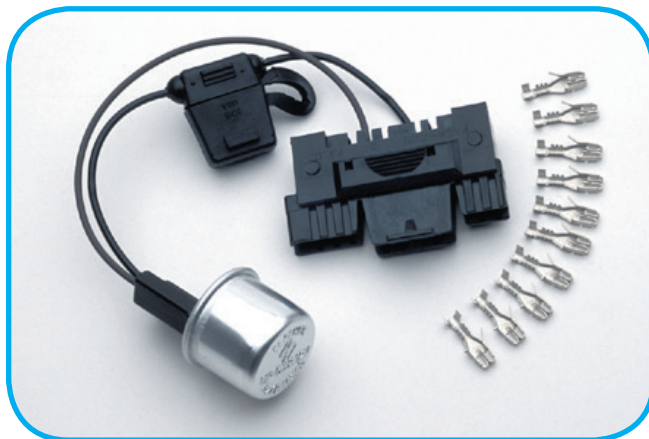

FR20118-1
4 Way Flasher/Hazard Kit
with Female Wiring Adapter



Figure A